



Serial ATA International Organization

Version 1.00
24-October 2007

Serial ATA Interoperability Program Revision 1.2 Agilent MOI for SATA RSG Tests

This document is provided "AS IS" and without any warranty of any kind, including, without limitation, any express or implied warranty of non-infringement, merchantability or fitness for a particular purpose. In no event shall SATA-IO or any member of SATA-IO be liable for any direct, indirect, special, exemplary, punitive, or consequential damages, including, without limitation, lost profits, even if advised of the possibility of such damages.

This material is provided for reference only. The Serial ATA International Organization does not endorse the vendor equipment outlined in this document.

TABLE OF CONTENTS

TABLE OF CONTENTS.....2

MODIFICATION RECORD3

ACKNOWLEDGMENTS4

INTRODUCTION.....5

GROUP 1: RSG REQUIREMENTS.....6

 TEST RSG-01: GEN1 (1.5Gb/s) RECEIVER JITTER TOLERANCE TEST..... 7

 TEST RSG-02: GEN2 (3.0Gb/s) RECEIVER JITTER TOLERANCE TEST..... 8

APPENDICES9

 APPENDIX A – GENERAL RESOURCE REQUIREMENTS 10

 APPENDIX B – SSG CALIBRATION PROCEDURE (USING AGILENT DSO81204 REAL-TIME DSO AS THE JMD) 13

 APPENDIX C – SSG CALIBRATION PROCEDURE (USING AGILENT N4903A J-BERT AS THE JMD) (INFORMATIVE) 17

 APPENDIX D – SSG CALIBRATION PROCEDURE (USING AGILENT 86100C DCA-J AS THE JMD) (INFORMATIVE) 19

 APPENDIX E – USING THE AGILENT N4903A J-BERT AS THE STRESSED SIGNAL GENERATOR (SSG) (INFORMATIVE) 24

 APPENDIX F – USING THE AGILENT 81133/4A PULSE/PATTERN GENERATOR AS THE STRESSED SIGNAL GENERATOR (SSG)..... 27

 APPENDIX G – USING THE AGILENT N4219B SERIAL ATA PROBE AS THE FRAME ERROR DETECTOR 30

 APPENDIX H – USING THE CRESCENT HEART SOFTWARE SATA-II PROBE AS THE FRAME ERROR DETECTOR 36

 APPENDIX I – SUGGESTED INITIAL AMPLITUDE AND DJ/RJ SETTINGS FOR VARIOUS SSG SETUPS (INFORMATIVE) 38

 APPENDIX J – USING THE AGILENT N5990A TEST AUTOMATION SOFTWARE OPTION 103..... 39

Serial ATA Logo Working Group

MODIFICATION RECORD

2007 Oct 24 (Version 1.00) FINAL APPROVED r1.2 RELEASE

Andy Baldman (UNH-IOL): Cover Page: Updated document version number to 1.00.

2007 Jul 12 (Version 1.00RC1) EDITORIAL UPDATE FOLLOWING 12JUL2007 RC APPROVAL

Andy Baldman (UNH-IOL): Cover Page: Updated document version number to 1.00RC.

2007 Jun 07 (Version 0.92) ADDITIONAL UPDATES, POST-IW3

Andy Baldman (UNH-IOL): Acknowledgements page: Added Hermann Stehling, for Bitifeye contributions of automation software.
RSG-01 and RSG-02: Added note at bottom of procedure to cover premature test abortion for cases when excessive errors are observed (i.e., >1000) for any test case, as per the UTD.
Appendix A: Added Agilent SMA cables and part numbers to equipment list.
Appendix A: Added model numbers of suitable equivalent Noisecom sources to equipment list.
Appendix A: Added E4432B sine source to equipment list as suitable DJ source.
Appendix I: Added initial starting settings for using E4432B as DJ source with 81134A SSG.
Added new Appendix (Appendix J), for Bitifeye automation software.

2007 Apr 28 (Version 0.90) MINOR UPDATES IN RESPONSE TO 17APR2007 REVIEW.

Andy Baldman (UNH-IOL): Cover Page: Updated SATA logo to trademarked version, and added CHS Frame Error Detector.
Entire Document: Changed Noisecom noise source model name from UFX-7110 to PNG-7110.
Appendix A: Changed amplitude procedure BACK to using LBP lone 0/1, rather than ALIGN minimum amplitude bits.
Renamed Appendix H to Appendix I.
Added new Appendix H for Crescent Heart Software Frame Error Detector.

2007 Apr 16 (Version 0.88) ADDITIONAL MAJOR UPDATES

Andy Baldman (UNH-IOL): Entire Document: Updated all DJ references to .270UI, from .320UI.
Entire Document: Removed all references to using 14dB splitters. (50/50 splitters are preferred, for better return loss and matching.)
Appendix A: Changed amplitude procedure to use ALIGN Minimum Amplitude Bit instead of LBP lone bit.
Appendix D: Cleaned up many typos, and moved J-BERT-specific SSG info into Appendix E.

2007 Apr 08 (Version 0.87) MAJOR UPDATE FOR REVISION 1.2 INTEROP PROGRAM

Andy Baldman (UNH-IOL): Entire document: Updated all UTD and MOI references to reflect Program Revision 1.2
RSG-01/02: Changed DJ frequencies from 5/10/62MHz to 10/33/62MHz per UTD updates.
Appendix A: Added 14dB pickoff tees to Table A-1, and changed Figure A-3 to a block diagram.
Appendix B: Completely overhauled, adding procedure for amplitude calibration using isolated Lone 1.
Appendices C, D, E: Made informative.
Appendix F: Major rewrite to include procedure for using Noisecom PNG-7110 noise source.

(PREVIOUS REVISIONS FOR 1.0 AND 1.1 INTEROP PROGRAMS)

2006 Nov 23 (Version 0.85) ADDITIONAL UPDATES

Michael Herz (Agilent): Added contents on an 81134A-based setup.

2006 Nov 22 (Version 0.84) ADDITIONAL MAJOR UPDATES

Andy Baldman (UNH-IOL): Created separate appendices for J-BERT, DCA-J, and real-time DSO calibration.
Created separate appendix for using 81134A-based setup (instead of J-BERT) for jitter generation.
Renumbered all Appendices as a result of above changes.
RSG-01/02: Replaced 'Pattern Generator' with 'SSG', to make more modular, and hardware independent.

2006 Nov 13 (Version 0.83) FIRST MAJOR UPDATE

Andy Baldman (UNH-IOL): Updated title page to new revision 1.1 naming conventions.
Added procedures to Appendix B to support multiple Jitter Measurement Devices for calibration purposes.
Added Appendix C for SATA Probe setup and configuration.

2006 Sep 24 (Version 0.81) INITIAL DRAFT RELEASE

Andy Baldman (UNH-IOL): Initial Release

ACKNOWLEDGMENTS

The Serial ATA Logo Working Group would like to acknowledge the efforts of the following individuals in the development of this document:

David Woolf
Andy Baldman
Dr. Michael Herz
Hermann Stehling

UNH InterOperability Lab
UNH InterOperability Lab
Agilent Technologies
Bitifeye Digital Test Solutions

djwoolf@iol.unh.edu
aab@iol.unh.edu
michael_herz@agilent.com
hermann.stehling@bitifeye.com

INTRODUCTION

The tests contained in this document are organized in order to simplify the identification of information related to a test, and to facilitate in the actual testing process. Tests are separated into groups, primarily in order to reduce setup time in the lab environment, however the different groups typically also tend to focus on specific aspects of product functionality.

The test definitions themselves are intended to provide a high-level description of the motivation, resources, procedures, and methodologies specific to each test. Formally, each test description contains the following sections:

Purpose

The purpose is a brief statement outlining what the test attempts to achieve. The test is written at the functional level.

References

This section specifies all reference material *external* to the test suite, including the specific subclauses references for the test in question, and any other references that might be helpful in understanding the test methodology and/or test results. External sources are always referenced by a bracketed number (e.g., [1]) when mentioned in the test description. Any other references in the test description that are not indicated in this manner refer to elements within the test suite document itself (e.g., “Appendix 6.A”, or “Table 6.1.1-1”)

Resource Requirements

The requirements section specifies the test hardware and/or software needed to perform the test. This is generally expressed in terms of minimum requirements, however in some cases specific equipment manufacturer/model information may be provided.

Last Modification

This specifies the date of the last modification to this test.

Discussion

The discussion covers the assumptions made in the design or implementation of the test, as well as known limitations. Other items specific to the test are covered here as well.

Test Setup

The setup section describes the initial configuration of the test environment. Small changes in the configuration should not be included here, and are generally covered in the test procedure section (next).

Procedure

The procedure section of the test description contains the systematic instructions for carrying out the test. It provides a cookbook approach to testing, and may be interspersed with observable results.

Observable Results

This section lists the specific observables that can be examined by the tester in order to verify that the PUT is operating properly. When multiple values for an observable are possible, this section provides a short discussion on how to interpret them. The determination of a pass or fail outcome for a particular test is generally based on the successful (or unsuccessful) detection of a specific observable.

Possible Problems

This section contains a description of known issues with the test procedure, which may affect test results in certain situations. It may also refer the reader to test suite appendices and/or other external sources that may provide more detail regarding these issues.

GROUP 1: RSG REQUIREMENTS

Overview:

This group of tests verifies receiver functionality under stressed-signal conditions, for the purposes of performing SATA-IO Interoperability Testing. These tests are limited to functionality which are covered by tests RSG-01 and RSG-02 (Section 2.15 of the Serial ATA Interoperability Program Unified Test Document Revision 1.2), and do not provide comprehensive coverage of all receiver tolerance requirements defined by the SATA v2.5 spec.

Serial ATA Logo Working Group

Test RSG-01: Gen1 (1.5Gb/s) Receiver Jitter Tolerance Test

Purpose: To verify that the receiver of the Product Under Test (PUT) can operate without error under stressed signal conditions while operating at 1.5Gb/s.

References:

- [1] Serial ATA Interoperability Program Revision 1.2 Unified Test Document, Section 2.15.1
- [2] Serial ATA Interoperability Program Revision 1.2 Pre-Test MOI, Appendix B (Framed COMP Pattern)

Resource Requirements: See Appendix A.

Last Modification: June 7, 2007

Discussion: Reference [1] specifies the basic requirements for Receiver Jitter Tolerance testing for the purposes of the SATA-IO Interoperability Program. These requirements are a subset of the complete set of requirements defined in the SATA standard. Note that this test requirement is only applicable to products running at 1.5Gb/s. For products that support 3.0Gb/s, this test is not required.

Test Setup: See Appendix A.

Test Procedure:

Note this test procedure assumes the user has already performed the initial system setup and calibration procedures outlined in Appendices A-H of this document.

- 1) Connect the PUT to the test system as outlined in Appendix A.
- 2) Configure the Stressed Signal Generator (SSG) to send the framed COMP pattern (see [2]) at 1.5Gb/s.
- 3) Turn the output of the generator OFF (i.e., disable all signal output).
- 4) Configure the PUT for BIST-L operation at 1.5Gb/s using the BIST Configuration Tool.
- 5) Turn the output of the SSG ON, but with jitter disabled (i.e., clean, unjittered pattern with nominal SATA amplitude).
- 6) Disconnect the BIST Configuration Tool from the power splitters, and terminate the unused splitter ports with 50-ohm SMA terminators.
- 7) Verify using the Frame Error Detector that the PUT is properly looping back the unstressed framed COMP pattern data without error.
- 8) Configure the SSG for Sinusoidal DJ at a frequency of 10MHz, with the proper DJ, RJ, and Amplitude values determined during the cal procedure for 1.5Gb/s operation. Enable jitter generation on the SSG output, and turn the SSG output ON.
- 9) Reset the counter on the Frame Error Detector.
- 10) Run the test for 20 minutes and record the number of frame errors detected by the Frame Error Detector.
- 11) Repeat steps 8-10 for the 33 and 62¹ MHz sinusoidal jitter frequencies.

Note that for any jitter frequency test case, if 'excessive' errors are observed (i.e., >1000), the test may be prematurely aborted, and a failing result assigned for that test case.

Observable Results:

- For all jitter frequencies, the number of frame errors observed should be zero.

Possible Problems: None

¹ If this test is carried out using a J-BERT as SSG, please note that the J-BERT pattern generator is not capable of generating 320mUI sinusoidal Jitter at 33 or 62MHz. At 62MHz a maximum of 121mUI can be generated with RJ turned on and a maximum of 300mUI can be generated with RJ turned off.

Serial ATA Logo Working Group

Test RSG-02: Gen2 (3.0Gb/s) Receiver Jitter Tolerance Test

Purpose: To verify that the receiver of the Product Under Test (PUT) can operate without error under stressed signal conditions while operating at 3.0Gb/s.

References:

- [1] Serial ATA Interoperability Program Revision 1.2 Unified Test Document, Section 2.15.2
- [2] Serial ATA Interoperability Program Revision 1.2 Pre-Test MOI, Appendix B (Framed COMP Pattern)

Resource Requirements: See Appendix A.

Last Modification: June 7, 2007

Discussion: Reference [1] specifies the basic requirements for Receiver Jitter Tolerance testing for the purposes of the SATA-IO Interoperability Program. These requirements are a subset of the complete set of requirements defined in the SATA standard. Note that this test applies only to products operating at 3.0Gb/s.

Test Setup: See Appendix A.

Test Procedure:

Note this test procedure assumes the user has already performed the initial system setup and calibration procedures outlined in Appendices A-H of this document.

- 1) Connect the PUT to the test system as outlined in Appendix A.
- 2) Configure the Stressed Signal Generator (SSG) to send the framed COMP pattern (see [2]) at 3.0Gb/s.
- 3) Turn the output of the generator OFF (i.e., disable all signal output).
- 4) Configure the PUT for BIST-L operation at 3.0Gb/s using the BIST Configuration Tool.
- 5) Turn the output of the SSG ON, but with jitter disabled (i.e., clean, unjittered pattern with nominal SATA amplitude).
- 6) Disconnect the BIST Configuration Tool from the power splitters, and terminate the unused splitter ports with 50-ohm SMA terminators.
- 7) Verify using the Frame Error Detector that the PUT is properly looping back the unstressed framed COMP pattern data without error.
- 8) Configure the SSG for Sinusoidal DJ at a frequency of 10MHz, with the proper DJ, RJ, and Amplitude values determined during the cal procedure for 3.0Gb/s operation. Enable jitter generation on the SSG output, and turn the SSG output ON.
- 9) Reset the counter on the Frame Error Detector.
- 10) Run the test for 20 minutes and record the number of frame errors detected by the Frame Error Detector.
- 11) Repeat steps 8-10 for the 33 and 62 MHz sinusoidal jitter frequencies.

Note that for any jitter frequency test case, if 'excessive' errors are observed (i.e., >1000), the test may be prematurely aborted, and a failing result assigned for that test case.

Observable Results:

- For all jitter frequencies, the number of frame errors observed should be zero.

Possible Problems: None

APPENDICES

Overview:

Test suite appendices are intended to provide additional low-level technical detail pertinent to specific tests contained in this test suite. These appendices often cover topics that are outside of the scope of the standard, and are specific to the methodologies used for performing the measurements in this test suite. Appendix topics may also include discussion regarding a specific interpretation of the standard (for the purposes of this test suite), for cases where a particular specification may appear unclear or otherwise open to multiple interpretations.

Test suite appendices are considered informative supplements, and pertain solely to the test definitions and procedures contained in this test suite.

Serial ATA Logo Working Group

Appendix A – General Resource Requirements

Purpose: To define the hardware/software requirements for performing the tests defined in this document.

References: None.

Last Modification: June 7, 2007

Discussion:

A.1 - Introduction

In order to perform receiver jitter tolerance testing on SATA transceivers, several pieces of equipment are needed. The primary functional components are as follows:

Component	Function	Device/Model
Stressed Signal Generator (SSG)	Generates jittered/stressed test signal	Agilent N4903 J-BERT (Gen2 only) or, Agilent 81133A (one channel) or 81134A (two channels) Pattern Generator, with either Agilent 33250A or E4432B signal generator (or equivalent), and suitable Noise Source (see list below).
Noise Source	Used as RJ modulation source (when using 81134A as SSG.)	NoiseCom PNG-7110. (Equivalent models include UFX/PNG-7107/08/09/10/12, and NC-6107/08/09/10/12)
BIST Generator (BISTGEN)	Used to enable BIST-L loopback mode of PUT	PC running Ulink DriveMaster software
Jitter Measurement Device (JMD)	Used to verify/calibrate SSG output	Agilent Infiniium DSO81304A 13GHz Real-Time DSO (Recommended) (Agilent 86100C w 54754A, or Agilent N4903 J-BERT May be used for informative purposes only.)
3-Way, 50/50 Resistive Power Splitter (PS)	Used to combine SSG output and BISTGEN signal into PUT receiver. (Also used to combine sinusoidal and random noise modulation sources into Delay Control input, when using 81134A as SSG)	Agilent 11636B or equivalent (2 needed for SSG outputs.) (1 additional needed if using 81134A as SSG)
Frame Error Detector (FED)	Used to monitor frame errors on PUT TX	Agilent 168xx or 169xx Logic Analyzer with one of the following modules: 16910, 16911, or 16950, and N4219B SATA Probe. or, Crescent Heart Software SATA-II Probe
Transition Time Converters (TTC)	Used to create SSG risetime of 100ps	Agilent N15435A (2 needed)
SATA-to-SMA Test Fixture	Used to convert SATA interface of PUT to SMA, for test instrument connections	Comax P/N H303000204A, or Crescent Heart TF-SATA-NE-XP, or Agilent N5421-26401
SMA Test Cables	Used for all connections	Agilent 15442-61601 (includes 4 cables) 8 total cables recommended.

Table A-1: Summary of Test Hardware Requirements

A.2- Basic Test Setup

Figure A-1 shows a Test Setup that supports both disconnect and non-disconnect PUT's. The BIST Configuration Tool is multiplexed into the TX and RX pairs of the PUT using power splitters, which allow non-disconnect-supporting PUT's to be put into BIST-L using the BIST Configuration Tool, then be sent the framed COMP test pattern into their RX from the SSG while being monitored on the TX by the Frame Error Detector. Once the PUT is placed into BIST-L loopback mode, the BIST Configuration Tool can then be physically removed from the setup in order to run the formal test.

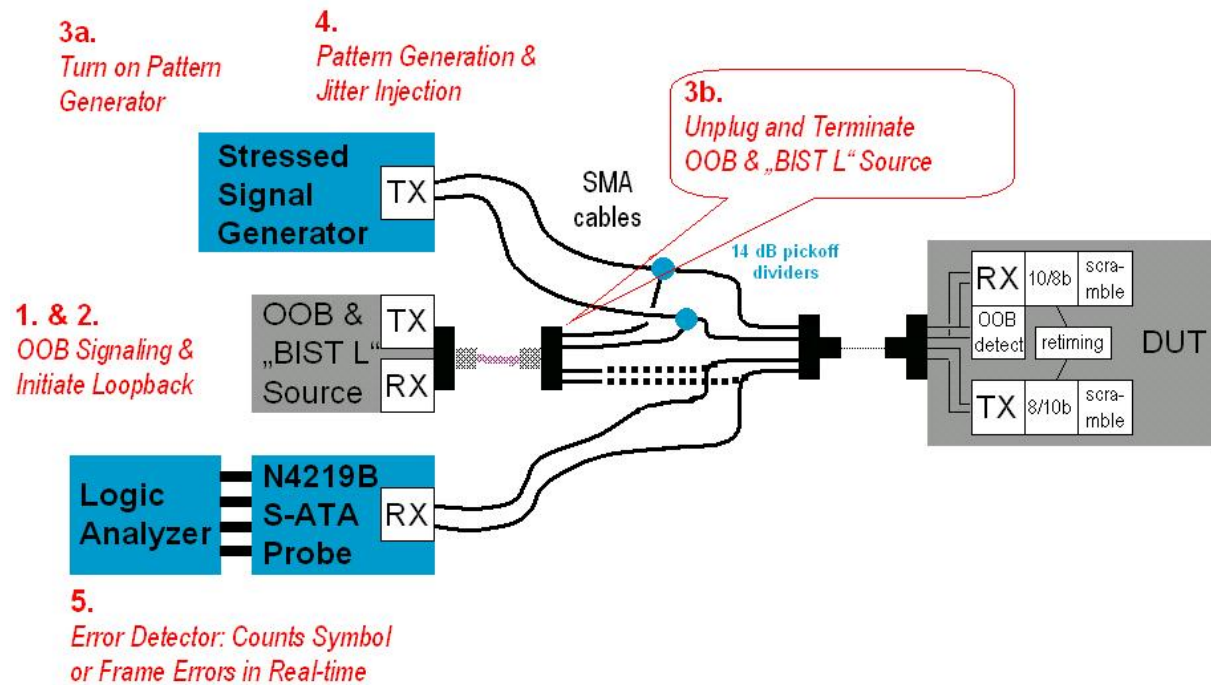

Figure A-1: Basic Test Configuration

Figure A-2 illustrates how either the Agilent 81133A or 81134A pulse and pattern generator (a) or the Agilent N4903A J-BERT would be used as a SSG (b). If the J-BERT is used as the SSG, no external parts are required. The setup using the 81133/4A requires two external sources to generate jitter. The outputs of the Agilent 33250A Function/Arbitrary Waveform Generator and a gaussian Noise Generator are connected via a power divider to the 81133/4A's Delay Control Input.

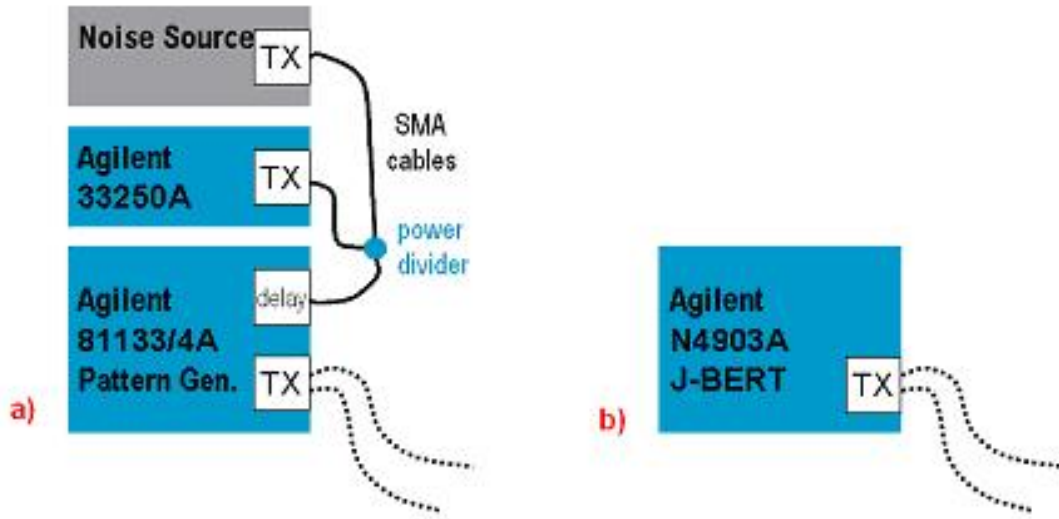

Figure A-2: (a) Use of Agilent 81133A or 81134A as SSG, or (b) Agilent N4903A J-BERT (Gen2 only)

A.3- Basic SSG Calibration Setup

Figure A-3 shows the general block diagram setup for performing the Stressed Signal Generator (SSG) calibration procedure. The output of the SSG is sent through the power splitters (with the unused splitter ports terminated into 50 ohms) and the signal characteristics at the end of the SMA cables (the reference plane) are verified and adjusted using a Jitter Measurement Device to be at the necessary levels required for the RSG tests.

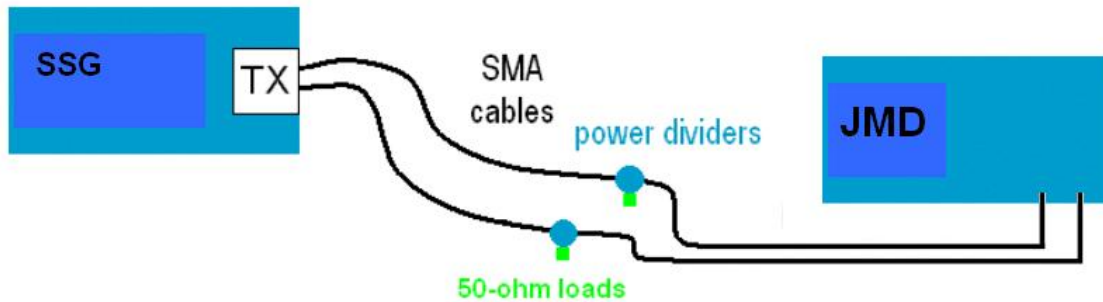

Figure A-3: Basic Calibration Setup

Serial ATA Logo Working Group

Appendix B – SSG Calibration Procedure (using Agilent DSO81204 Real-Time DSO as the JMD)

Purpose: To define a procedure for verification and calibration of the stressed signal generator setup, using the Agilent Infiniium DSO81204 Real-Time DSO as the Jitter Measurement Device.

References:

[1] Serial ATA Interoperability Program Revision 1.2 Unified Test Document, Section 2.15

Last Modification: April 8, 2007

Discussion:

Prior to running the actual stressed receiver tests, it is necessary to perform several steps to verify and calibrate the test system, in order to ensure that the signal delivered to the receiver of the PUT exhibits the proper type and amount of stress for the each test, as defined in [1].

First, we must verify that the SSG is providing the proper amounts of TJ and RJ at the reference plane. Note that the reference plane in this case is the end of the SMA cables, where they connect to the fixture that interfaces to the PUT.

The setup and calibration procedure is as follows:

B.1 - Configure the SSG to send the Framed COMP signal:

- See Sections E.2 (for J-BERT) or F.2 (for 81134A) of this MOI.

B.2 - Calibrate the Differential Amplitude at the Reference Plane:

The amplitude calibration procedure requires measuring the amplitude of two particular bits contained in the framed COMP pattern, namely the Lone 0 and Lone 1 bits contained in the SATA Lone Bit Pattern (LBP). Performing this measurement requires isolating these bits on the scope so that the amplitude of only those bits can be measured. To do this, we will use a reference signal from the SSG, which is synchronized to the start of the Framed COMP pattern, as a trigger reference to trigger the scope. The delay can then be adjusted to isolate the desired bits, perform the amplitude measurement, and adjust accordingly.

This procedure assumes that the SSG possesses a trigger out signal, which can output a rising edge at the beginning of the pattern. (For details regarding particular SSG's, refer to Appendices E (J-BERT) and F (81134A) of this MOI.)

First, we will set up and connect the hardware:

- Connect the **Trigger Out** signal of the SSG to the **Channel 4 input** of the DSO.
- Using the diagram in **Appendix F, Figure F-1** as a guide, disconnect any SMA cables from the BISTGEN side of the splitters at the output of the SSG, and cap the splitter ports with 50-ohm SMA terminators.
- On the PUT side of the splitters, leave the cables attached to the splitters, but disconnect them from the PUT, and put them into the DSO (+ **into CH1**, and – **into CH3**).
- Load the **Framed COMP pattern** into the SSG, and set the initial amplitude. (See E.2 for J-BERT and F.2 for 81134A).

Serial ATA Logo Working Group

Next, configure the DSO:

- Assuming the DSO has been properly deskewed, press **Default Setup** to reset the DSO. Connect the TX+ and TX- outputs of the SSG to Channels 1 and 3 of the DSO, respectively.
- On the DSO, create a math waveform (CH1-CH3) on **Function 4** for the differential signal by going to **Analyze->Math** to set up the function. Select the **f4** function, click the **Display On** checkbox (so it is selected), then select **Subtract** in the **Operator** menu, then select **Channel 1** for **Source 1**, and **Channel 3** for **Source 2**. Click **Close**, then manually turn off the individual Channels 1 and 3 using the front panel hard buttons so that only the math waveform remains on the screen.
- On the front panel trigger setup of the DSO, set **Trigger Mode to Edge**, **Source to CH4**, and **Slope to Positive**. Set the trigger level to 0mV using the front panel knob.
- Turn the **Channel 4** display ON using the front panel “4” button.
- Using the front panel **Vertical Gain** knobs, scale Channels 1 and 3 so they span as much of the screen as possible. Keep the same setting for both channels. Then turn both channel displays **OFF** using the front panel “1” and “3” buttons. You should now see the rising edge trigger pulse on Channel 4, and the differential math waveform. Once you have verified that you have a stable trigger on CH4, turn the CH4 display **OFF** using the front panel button.
- Set the scope’s **Horizontal** setting to **2ns/div**. Then, using the **Horizontal Delay knob** on the front panel, scroll through the waveform until you see the **Lone 1 pattern**, shown below. (Note you may have to scroll for a while until you see it. It is a 00001000 pattern followed by 110 110. Look for the lone “spike” followed by two “fangs”.) When you have it isolated on the screen, it should look like Figure B-2, below.

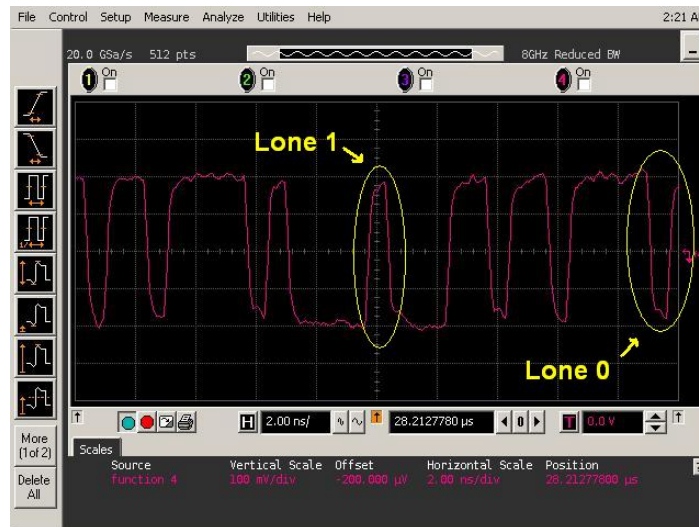

Figure B-2: Isolated Lone 1 and Lone 0 Bits

- Once you have the Lone 1 isolated, we will now do a histogram measurement to determine the amplitude. Zoom in to **200ps/div**. Then go to **Analyze->Histogram** to open the histogram configuration screen. Check the **Enable Histogram** box. Set **Histogram Source** to **Waveform**. Set **Orientation** to **Vertical**. Then hit **Close**.

Serial ATA Logo Working Group

- Now, manually **drag the markers** on the screen to isolate the amplitude of the Lone 1 bit. Move the two **vertical markers** (i.e., the horizontal bars) to **just above and below the top of the bit**.
- For the **horizontal markers** (i.e., the vertical bars), we must position them at approximately the **40% and 60% UI width** points, to include only those samples in the histogram. To do this, we must roughly measure the width of the bit. Use the zero crossing points to do this, noting the width of the spacing between the zero crossings in terms of divisions. Manually position the histogram cursors at the 40% and 60% time points. When you are finished, your display should resemble the image shown in Figure B-3, below.

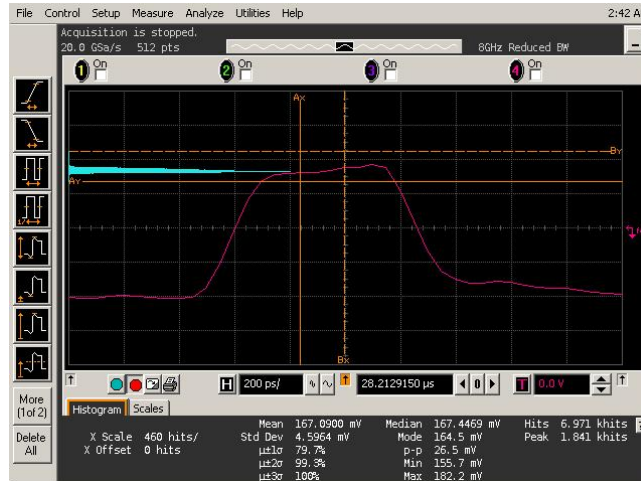

Figure B-3: Amplitude Histogram Measurement of the Lone 1 Bit

- Adjust the amplitude setting of the SSG so that the Mean histogram amplitude is **162.5mV (Gen1)**, or **137.5mV (Gen2)**. Record the SSG settings that produce the desired amplitude at the reference plane.
- Repeat the histogram amplitude measurement procedure for the **Lone 0 bit**, and verify that the differential amplitude between the Lone 0 and Lone 1 bits is **325mV(Gen1)**, or **275mV(Gen2)**.

B.3 - Verify a 100ps Rise Time at the Reference Plane:

- With the DSO still set up to display the differential waveform as **Function 4**, load the **MFTP** pattern into the SSG.
- Perform a risetime measurement on the DSO by going to **Measure->Time->Rise Time**. You should now see the risetime result at the bottom of the screen. However, note that this is the 10-90% risetime, not 20-80% as defined by SATA. To change the risetime algorithm, right click anywhere in the risetime result area, and select **“Change Thresholds...”**. Under the **Thresholds** pulldown menu, select **20%,50%,80% of Top,Base**, and click **Close**. You should now see the correct 20-80% risetime value in the measurement result.

B.4 - Verify that the Skew at the Reference Plane is Less Than 10ps:

- Press **Default Setup** to reinitialize the DSO.

Serial ATA Logo Working Group

- Turn **Channel 3 ON** using the selector button on the front panel.
- Adjust **Channels 1 and 3** to **200mV/div** using the **Vertical** knobs on the front panel.
- Zoom in to **10ps/div**, using the **Horizontal** knob on the front panel.
- Invert the Channel 3 signal by going to **Analyze->Math**, and selecting function **f3**. Check the **Display On** checkbox, and select **Invert** as the Operator, and **Channel 3** as Source 1.
- Turn Channel 3 **OFF** using the selector button on the front panel.
- Visually compare the zero crossing times between the **Channel 1** and **Function 3** waveforms, and verify that the difference between them is less than 10ps (i.e., one horizontal division).
- If the skew is more than 10ps, the SMA cables from the SSG are the likely cause. Try different cables (or change one of the two in the pair) and re-measure the skew until the result is less than 10ps.

B.5 - Calibrate RJ to 0.180 UI at the Reference Plane:

To measure jitter using the DSO, we will use the **RJ DJ Setup Wizard** to set up the instrument:

- Go to **Analyze->Jitter**, then click the **RJ DJ Setup Wizard** button.
- Click **Next**, then **Next** again.
- Set the **Source** to **Function 4**, Pattern Length to **Arbitrary**. Click **Next**.
- Click **Next** again to skip past the **Measurement Setup** screen.
- Under the **Clock Recovery** screen, set **Constant Frequency, 1.5 or 3.0Gb/s**, and select **Semi-Automatic**, as before. Click **Next**.
- Click **Next** again to skip past the **Thresholds** screen.
- On the **Acquisition** screen, you will specify sample rate and memory depth setting (This should be **40GS/s** and **131Kpts** for **Gen1**.) Then click **Next**.
- Click **Finish** to exit the Wizard. You can also click **Close** on the Jitter window to get rid of that.

The scope should start running, and you should see the RJ/DJ screen accumulating values. Look at the **RJ(RMS, narrow)** result at the bottom of the scope screen. Adjust the RJ of the SSG until this value is **8.57ps RMS for Gen1** and **4.285ps RMS for Gen2** (See Appendix I for suggested initial SSG settings). Record the SSG settings that produce the desired RJ value on the DSO display.

B.6 - Add Sinusoidal DJ to Create .450 UI TJ at the Reference Plane:

- With the DSO still set up for the DJ/RJ measurement, increase the DJ of the SSG until the TJ is **0.450UI** (note this is **300ps for Gen1** and **150ps for Gen2**). Record the SSG settings that produce the .450UI TJ value on the DSO display.

B.7 – Verification of SSG Output for Gen2 (3.0Gb/s) Rate

The setup and calibration procedure for the stressed Gen2 (3.0Gb/s) signal is identical to the procedure described above for the Gen1 signal, except that the bit rate must be set for 3.0Gb/s, and the amplitude must be 275mVppd. Repeat the Gen1 procedure to determine the proper Gen2 SSG amplitude and RJ settings, as well as the DJ settings for the 10, 33, and 62MHz jitter frequencies.

Serial ATA Logo Working Group

Appendix C – SSG Calibration Procedure (using Agilent N4903A J-BERT as the JMD) (Informative)

Purpose: To define a procedure for verification and calibration of the stressed signal generator setup, using the Agilent N4903A J-BERT as the Jitter Measurement Device.

References:

[1] Serial ATA Interoperability Program Revision 1.2 Unified Test Document, Section 2.15

Last Modification: April 17, 2007

Discussion:

Prior to running the actual stressed receiver tests, it is necessary to perform several steps to verify and calibrate the test system, in order to ensure that the signal delivered to the RX port of the PUT exhibits the proper type and amount of stress for the each test, as defined in [1].

First, we must verify that the SSG is providing the proper amounts of DJ and RJ at the reference plane. Note that the reference plane in this case is the end of the SMA cables, where they connect to the fixture that interfaces to the PUT.

The setup and calibration procedure is as follows:

C.1 - Configure the SSG to send a Framed COMP signal:

- See Sections E.2 (for J-BERT) or F.2 (for 81134A) of this document.

C.2 - Calibrate the Differential Amplitude at the Reference Plane:

- Connect the TX+ and TX- outputs of the SSG to the positive and negative DATA IN ports of the J-BERT.
- On the J-BERT, go to **Analysis->Eye Diagram**, and press **Start** to build an eye. You should see the eye measurement results appear below the eye diagram. Read the **Eye Amplitude** value. This is the differential amplitude.

C.3 - Verify a 100ps Rise Time at the Reference Plane:

- The procedure for performing the risetime verification using the J-BERT is identical to the Differential Amplitude calibration (see C.2 above). The risetime value is also reported in the results of the Eye Diagram measurement.

C.4 - Verify that the Skew at the Reference Plane is Less Than 10ps:

- *TBD - (Describe procedure using Output Timing analysis tool to compare skew of TX+ and TX- signals.)*

C.5 - Calibrate RJ to 0.180 UI at the Reference Plane:

(Eye Diagram method. Can also use Output Timing method, see below.)

- Go to **Analysis->Eye Diagram** on the J-BERT, and press **Start** to build an eye. You should see the eye measurement results appear below the eye diagram. Read the **Pk-Pk Jitter** value. This is the TJ, but not at the proper BER level of 1E-12. To change this, **right click** on the measurement, and select **Properties**. Under the **View** tab, in the **Calculate Measurement Results for** area,

Serial ATA Logo Working Group

make sure **BER Threshold** is selected, and select **1E-12** from the pulldown menu. Press **OK**. Note it may take a while for the measurement to complete, but eventually you should see a TJ result for 1E-12 in the result area.

(Output Timing method. Preferred method, faster than building complete eye.)

- Go to **Analysis->Output Timing** on the J-BERT.
- (Set optimum settings under Properties.)
- Press **Start** to build a bathtub curve.

C.6 - Add Sinusoidal DJ to Create .450 UI TJ at the Reference Plane:

- *(Procedure TBD.)*

C.7 – Verification of SSG Output for Gen2 (3.0Gb/s) Rate

The setup and calibration procedure for the stressed Gen2 (3.0Gb/s) signal is identical to the procedure described above for the Gen1 signal, except that the bit rate must be set for 3.0Gb/s, and the amplitude must be 275mVppd. Repeat the Gen1 procedure to determine the proper Gen2 SSG amplitude and RJ settings, as well as the DJ settings for the 10, 33, and 62MHz jitter frequencies.

Serial ATA Logo Working Group

Appendix D – SSG Calibration Procedure (using Agilent 86100C DCA-J as the JMD) (Informative)

Purpose: To define a procedure for verification and calibration of the stressed signal generator setup, using the Agilent 86100C DCA-J as the Jitter Measurement Device.

References:

- [1] Serial ATA Interoperability Program Revision 1.2 Unified Test Document, Section 2.15

Last Modification: April 17, 2007

Discussion:

Prior to running the actual stressed receiver tests, it is necessary to perform several steps to verify and calibrate the test system, in order to ensure that the signal delivered to the RX port of the PUT exhibits the proper type and amount of stress for the each test, as defined in [1].

First, we must verify that the SSG is providing the proper amounts of DJ and RJ at the reference plane. Note that the reference plane in this case is the end of the SMA cables, where they connect to the fixture that interfaces to the PUT.

The setup and calibration procedure is as follows:

D.1 - Configure the SSG to send an MFTP signal:

- See Sections E.2 (for J-BERT) or F.2 (for 81134A) of this document.

D.2 - Calibrate the Differential Amplitude at the Reference Plane:

- Initialize the DCA-J by pressing the **Default Setup** button. (Note this will automatically select **Oscilloscope Mode**, which is what we will use for the amplitude measurement.)
- Press the **Autoscale** button to get an eye on the screen.
- Configure a differential trace by going to **Measure->Math**, and turn on **Function 1**. Configure Function 1 to **subtract** Channels 1 (Source 1) and 2 (Source 2). Then, turn Channel 1 **off** using the **front panel selector button** so that only Function 1 remains. Press **Autoscale** again to optimize Function 1.
- Measure the amplitude by going to the **Amplitude** tab on the left side of the DCA-J screen, and selecting the **Vamp_{td}** measurement. The differential amplitude value should appear at the bottom of the screen.
- Adjust the SSG amplitude (see E.3 and F.3) until the measured amplitude reads **325mV_{ppd} (Gen1)**, or **275mV (Gen2)**. Record the SSG amplitude setting that yields the desired output amplitude at the reference plane.

D.3 - Verify a 100ps Rise Time at the Reference Plane:

- With the DCA-J still in Oscilloscope Mode, switch to **Eye/Mask Mode** by pressing the corresponding button just to the right of the display.
- Measure the rise time by going to the **Eye Meas** tab on the left side of the screen, and selecting **More**, then the **Rise Time** measurement. The rise time value should appear at the bottom of the screen. Note that the value displayed by default is the **10-90% value**, but we want the **20-80% value** for SATA measurements. Change the measurement configuration by pressing the **Setup&Info** button on the right side of the **Measure** tab where the risetime value is displayed. Select **Configure Meas...**, and select the **20%, 50%, 80%** radio button, then hit **Close**. Now, verify that the measured rise time is **100ps**.

D.4 - Verify that the Skew at the Reference Plane is Less Than 10ps:

- Reinitialize the DCA-J by pressing **Default Setup** again. Turn Channel 2 **On** using the front panel selector button. Select **Eye/Mask Mode** on the front panel, and press **Autoscale**. You should see the two Channels' eyes appear on the display.
- Zoom in on the zero crossing area using the **Horizontal** knob. (A setting of about **10ps/div** should work well.) Turn on Marker 1 using the leftmost vertical **Marker** button on the front panel, and assign it to **Channel 1**. Assign the second vertical marker (the dashed one 3rd from the left on the front panel) to **Channel 2**. Line Marker 1 up with the Channel 1 zero crossing point, and do the same for Marker 2/Channel 2. Verify that the skew is no more than **10ps**. If the skew is excessive, try replacing one or both of your cables, and remeasuring the skew. (Note you'll probably also have to repeat the amplitude calibration also, as different cables will have slightly different losses.) See the figure below for a sample screenshot of the skew measurement.

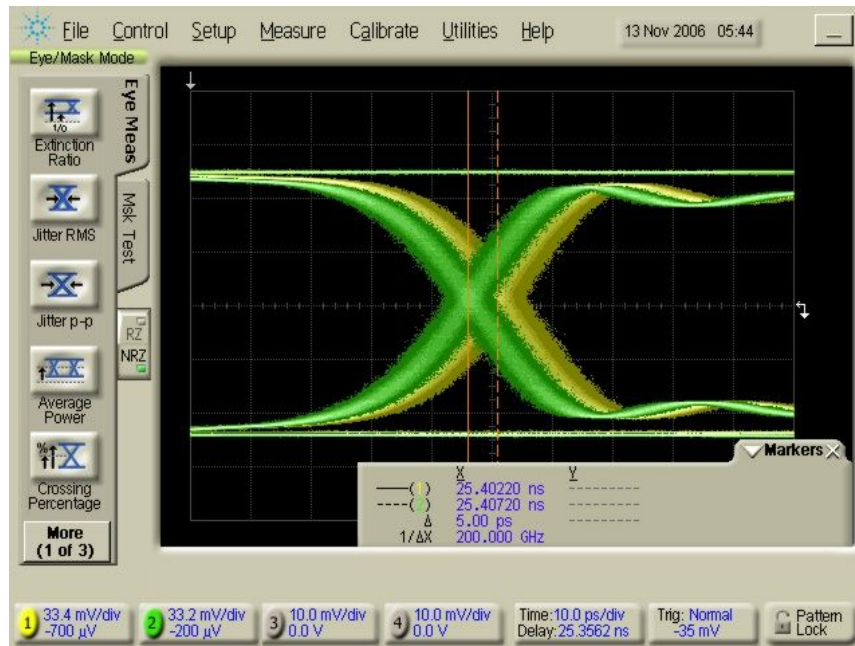

Figure D-1: Skew measurement screenshot

D.5 - Calibrate RJ to 0.180 UI at the Reference Plane:

For this procedure, we will set the initial SSG RJ to be close to the desired range, and then we will measure and fine-tune it using a jitter measurement instrument.

(Note: The first 'Jitter Mode' procedure below tends to slightly overestimate RJ (i.e., it measures more than what the J-BERT's RJ value is configured for, when using the J-BERT as the SSG.) See the alternate 'Eye/Mask mode' procedure below, which tends to better match the J-BERT's RMS RJ setting.)

Serial ATA Logo Working Group

Procedure using Jitter mode:

- Connect the positive and negative output signals from the SSG to Channels 1 and 2 of the DCA-J, respectively. Also, connect the single ended clock signal from the SSG to the **Front Panel Trigger** input of the DCA-J. Press **Default Setup** on the **DCA-J** to reinitialize the instrument.
- Configure a differential trace by going to **Measure->Math**, and turn on **Function 4**. Configure Function 4 to **subtract** Channels 1 (Source 1) and 2 (Source 2). Then, turn Channel 1 **off** using the **front panel selector button** so that only Function 4 remains. Press **Autoscale** again to optimize Function 4.
- Enable Jitter mode by pressing the **Jitter Mode** button on the front panel. The DCA-J should auto-detect the pattern and display a jitter summary on the screen. Look at the **TJ(1E-12)** result, which should read around **140ps** or so. The **DDJ(p-p)** result should be **100fs** or less (if it isn't, your cables are skewed, or there is some other source of DJ. Check your setup.) The **RJ(rms)** value should read around **9-10 ps**.
- Change the **units** of the jitter results to **UI** by clicking on the **Setup&Info** button, selecting **Config Meas...**, and changing the **Jitter Mode Units radiobutton** to **Unit Interval**. Then press **Close**.
- Adjust the SSG's **RJ Amplitude** until the **TJ(1E-12)** value on the DCA-J reads **180mUI**. Record the SSG setting that results in the properly calibrated 8.57ps RMS value at the reference plane.

Alternate method using Eye/Mask mode. (Preferred method):

- Connect the positive and negative output signals from the SSG to Channels 1 and 2 of the DCA-J, respectively. Also, connect the single ended clock signal from the SSG to the **Front Panel Trigger** input of the DCA-J. Press **Default Setup** on the **DCA-J** to reinitialize the instrument.
- Configure a differential trace by going to **Measure->Math**, and turn on **Function 4**. Configure Function 4 to **subtract** Channels 1 (Source 1) and 2 (Source 2). Then, turn Channel 1 **off** using the **front panel selector button** so that only Function 4 remains. Press **Autoscale** again to optimize Function 4.
- Enable Eye/Mask mode by pressing the **Eye/Mask Mode** button on the front panel. The DCA-J should auto-detect the pattern and display the RMS measurement result on the screen, which should read around **8.0 to 8.5ps**.
- On the SSG, adjust the **RJ Amplitude** until the **Jitter RMS(f4)** value on the DCA-J reads **8.57ps**. Record the SSG setting that results in the properly calibrated 8.57ps RMS value at the reference plane.

D.6 - Add Sinusoidal DJ to Create .450 UI TJ at the Reference Plane:

Now that the RJ has been calibrated, the DJ must be added to calibrate TJ to at the specific jitter frequencies required for the test.

(Note: This is an older procedure for calibrating sinusoidal DJ, not TJ. Informative use only.)

(Note: Jitter mode cannot be used here, as jitter is too large in some cases and DCA-J gives an error, saying to decrease the jitter, and/or retard the edges. Therefore Eye/Mask mode must be used instead.)

- Connect the SSG to the DCA-J, and configure **Function 4** to display the differential signal. (See first two bullets of **D.5**.)
- Turn off all jitter from the SSG output and press **AutoScale** on the DCA-J.
- On the SSG, enable only the **DJ** component, and set to approximately **.270UI at 10MHz**. (See Appendix I for SSG initial settings.)

Serial ATA Logo Working Group

- Upon enabling the DJ, the DCA-J display should resemble the following:

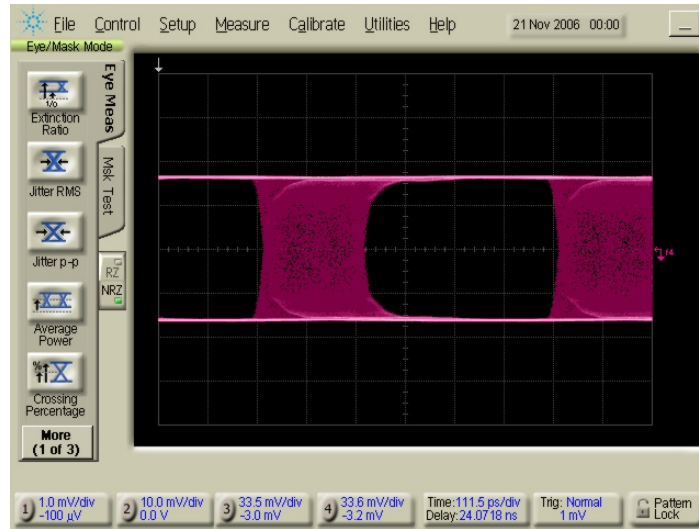

Figure D-2: DCA-J display during DJ measurement

- Now, we will set a histogram to measure the peak-to-peak width of the eye. (Note: One could also use the Jitter p-p automatic measurement shown on the left side of the DCA-J screen above, however this sometimes takes a while to converge to a stable value.) To set the histogram, go to **Measure->Histograms->Configure**. In the dialog that displays, check the **Histograms ON**, and **Show Border** checkboxes, then hit **Close**.
- Adjust the histogram by going to **Measure->Histograms->Window**, and adjusting the window boundaries to select only a thin horizontal slice of the waveform zero crossing. When finished, your display should resemble the following:

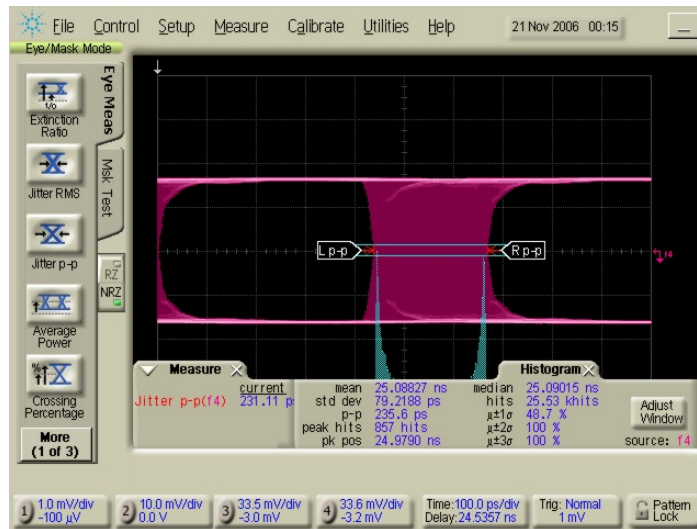

Figure D-3: Using histogram to measure pk-pk DJ

Serial ATA Logo Working Group

- The histogram may now be used to measure the pk-pk jitter due to the sinusoidal DJ. Adjust the J-SSG value until the DCA-J reads .270UI. Record the final SSG setting that yields the properly calibrated DJ value at the reference plane.
- Repeat the above steps for DJ frequencies of 33MHz and 62MHz. Be sure to record the SSG settings for each frequency.

D.7 – Verification of SSG Output for Gen2 (3.0Gb/s) Rate

The setup and calibration procedure for the stressed Gen2 (3.0Gb/s) signal is identical to the procedure described above for the Gen1 signal, except that the bit rate must be set for 3.0Gb/s, and the amplitude must be 275mVppd. Repeat the Gen1 procedure to determine the proper Gen2 SSG amplitude and RJ settings, as well as the DJ settings for the 10, 33, and 62MHz jitter frequencies.

Serial ATA Logo Working Group

Appendix E – Using the Agilent N4903A J-BERT as the Stressed Signal Generator (SSG) (Informative)

Purpose: To document the various necessary setup and configuration procedures required when using the Agilent N4903A J-BERT as the Stressed Signal Generator.

References:

[1] Serial ATA Interoperability Program Revision 1.2 Unified Test Document, Section 2.15

Last Modification: April 8, 2007

Discussion:

There are multiple suitable options available for generating the stressing signal required for performing SATA Receiver Tolerance testing. One option is to use the Agilent N4903A J-BERT. This appendix documents the necessary procedures for setting up and configuring the J-BERT for RSG testing. (Note these procedures are referenced by other procedures in this document.)

E.1 – General SSG Setup:

Because the J-BERT is an integrated system, no external active signal generating/modulating devices are needed in order to create the stressed SATA signaling. The N4903A J-BERT is shown below:

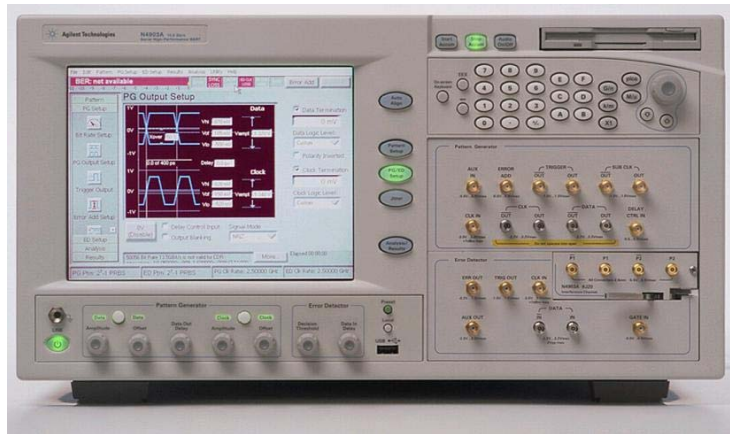

Figure E-1: N4903A J-BERT

Note that the only external components that are needed are two Agilent 15435A Transition Time Converters (TTC's), which are needed to slow down the output risetime of the J-BERT to the required SATA levels (100ps 20/80%), and two 3-way resistive splitters, used to mux in the BISTGEN source, and also to monitor the test signal. These are attached directly to the DATA outputs of the J-BERT (J-BERT into TTC's into splitters. See similar setup in Figure F-1 for 81134A.)

E.2 - Configuring the SSG to send an MFTP signal:

- (Optional): If one does not exist, you must create a new MFTP pattern file. This can be done by going to **Pattern->Pattern Editor**, then selecting the **NEW** icon. Enter "**MFTP 20 bits**" into the **Description** field, and "**20**" into the **Length** field. The pattern type should be **Standard**. Then, use the cursor and keyboard to edit the pattern to read "**1100 1100 1100 1100 1100**". Click the **Save As** icon, and save it to file *MFTP20.ptn*.
- Load the pattern by going to **Pattern->Pattern Select**, and select the **User Pattern from File** radiobutton, and click the **Browse** button. Select the *MFTP20.ptn* pattern and press **OK**. Also, make sure the "**Error Detector Pattern tracks the Pattern Generator Pattern**" box is checked, then press **OK**.

Serial ATA Logo Working Group

- Configure the initial J-BERT data amplitude by going to **PG Setup->PG Output Setup**, and entering a **0mV** value for **Vof**, and **375mV** for **Vampt**. For the Clock output, enter **0mV** for **Vof**, and **500mV** for **Vampt**.
- Next, we will set the J-BERT bit rate, by going to **PG Setup->Bit Rate Setup**. Make sure **Clock Source** is set to **Internal**, **Sub Rate Clock Divider** is **2**, and enter **1.5Gb/s** for the rate. (If you haven't already done so, add a preset for this rate by selecting the **Add Preset** button on the right.)
- Turn on the J-BERT transmitter by pressing the **Data** button on the front panel (below the display).

E.3 – Adjusting the Output Amplitude

- To adjust the output amplitude, go to **PG Setup->PG Output Setup**, adjust the **Vampt** value until the measured amplitude reads the desired value, as shown below.

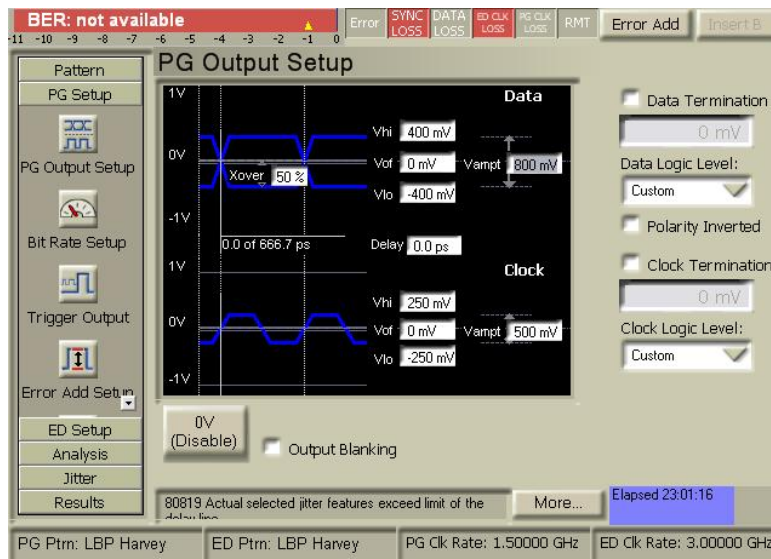

Figure E-2: J-BERT Amplitude Setup Screen

E.4 – Adjusting the Random Jitter (RJ)

- To set the initial RJ output value of the J-BERT, go to **Jitter->Jitter Setup**. Start by selecting the master jitter **Enable** checkbox in the upper left corner of the screen. Select the **200ps delay line**, and check only the purple **Random** checkbox. Under the Random settings, specify **12.8 mUI** for the **Amplitude (rms)** value. Make sure that the **10MHz high-pass** and **500MHz low-pass** filters are **OFF**. The p-p Amplitude value should read **179.2mUI**. Note that this is just below the desired output value of 180mUI.

Serial ATA Logo Working Group

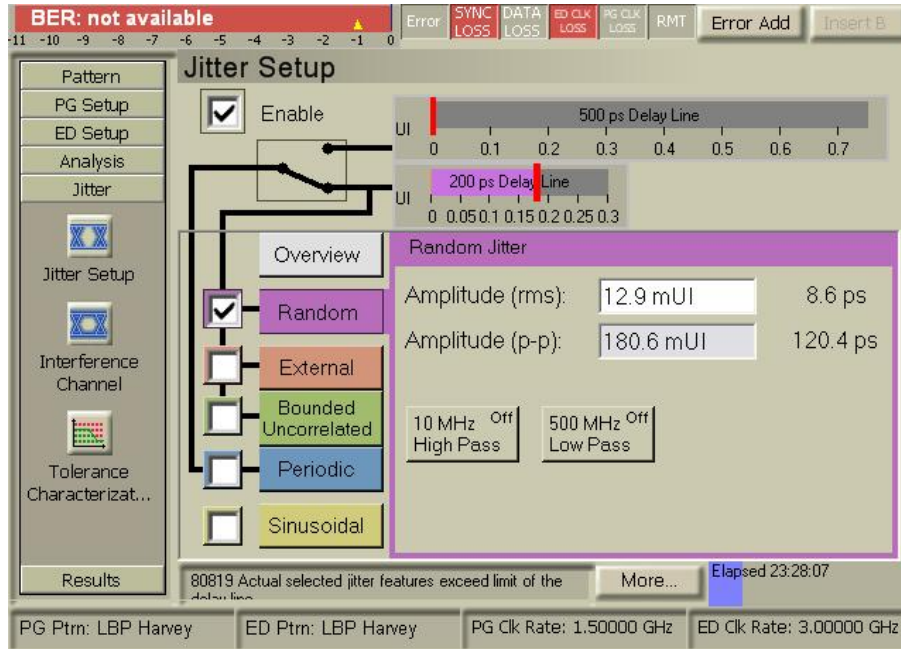

Figure E-3: J-BERT Jitter Setup Screen (RJ)

E.5 – Adjusting the Deterministic Jitter (DJ)

- To adjust the Deterministic Jitter on the J-BERT, go to **Jitter->Jitter Setup** as shown below, and adjust the **Amplitude** and **Frequency** values as desired.

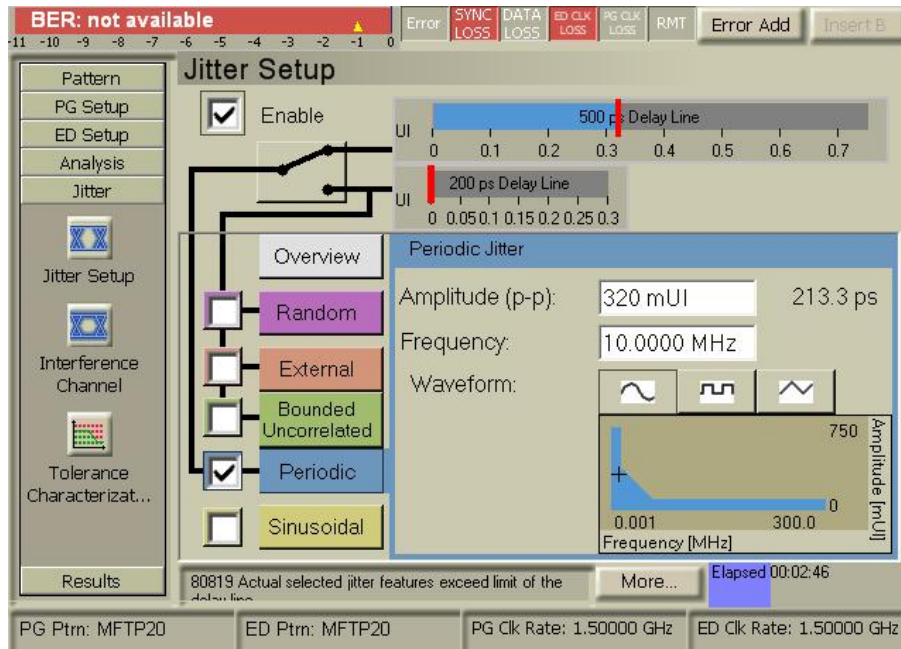

Figure E-4: J-BERT Jitter Setup Screen (DJ)

Serial ATA Logo Working Group

Appendix F – Using the Agilent 81133/4A Pulse/Pattern Generator as the Stressed Signal Generator (SSG)

Purpose: To document the various necessary setup and configuration procedures required when using the Agilent 81133A or 81134A-based system as the Stressed Signal Generator.

References:

[1] Serial ATA Interoperability Program Revision 1.2 Unified Test Document, Section 2.15

Last Modification: April 17, 2007

Discussion:

There are multiple suitable options available for generating the stressing signal required for performing SATA Receiver Tolerance testing. One option is to use a system built around the Agilent 81133/4A Pulse/Pattern Generator. This appendix documents the necessary procedures for setting up and configuring the system for RSG testing. (Note these procedures are referenced by other procedures in this document.)

F.1 – General SSG Setup:

The general setup using the 81134A and associated components is shown below:

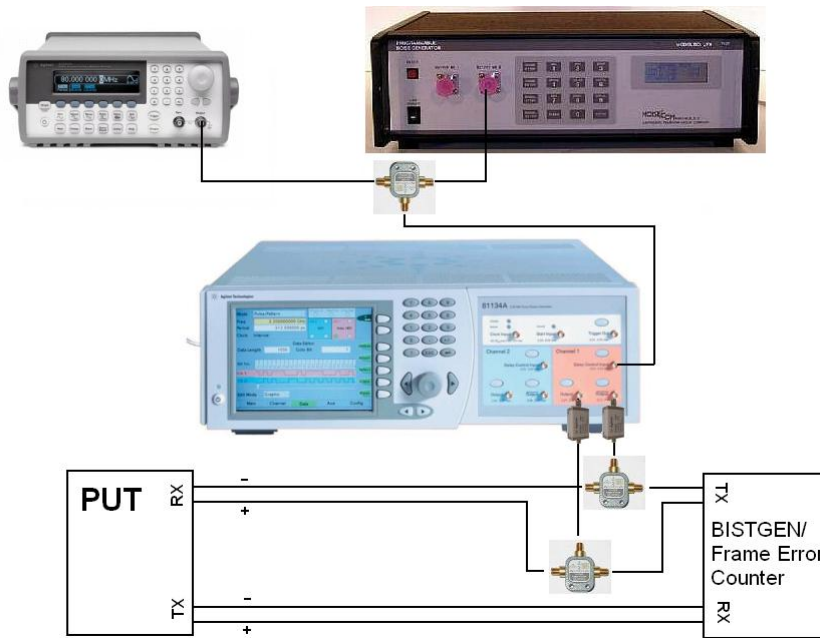

Figure F-1: Agilent 81134A Pulse and Pattern Generator, Agilent 33250A Function/Arbitrary Waveform Generator, and Noisecom PNG-7110 Noise Generator

Note the use of the Agilent 15435A Transition Time Converters and power splitters on the output of the 81134A. The Transition Time Converters are needed to slow the risetime of the 81134A's output to 100ps (20/80%).

The power splitters are standard 3-way resistive power splitters. While earlier versions of this MOI used 14dB pickoff tee dividers, it was since determined that the 14dB pickoff tees are not ideally impedance matched (as the pickoff port is 220 ohms), which causes an undesirable discontinuity, resulting in signal reflections that show up as pulse distortions in the final signal. The pickoff tees were originally desirable due to the fact that the through path (i.e., non-pickoff) provided a lower loss path than when 3-way splitters were used, allowing more of the BISTGEN signal to get through to the PUT. However it has since been found that this is less of an issue than was

Serial ATA Logo Working Group

initially thought, and in the worst-case, if the setup is being used with a BISTGEN that has especially low output amplitude (such that the PUT can't detect the BISTGEN signal after passing through the splitters), external amplification may be used to boost the BISTGEN output (Picosecond Pulse Labs 5828-108 amplifiers are well-suited for this purpose).

Note that the use of resistive splitters is only necessary due to the existence of certain PUT's, which do not support being disconnected/reconnected after being configured for BIST-L mode. (If the PUT is known to not have this issue, the splitters could be removed from the setup entirely. However, given that this MOI must account for the possibility of testing PUT's that do not support disconnect, the procedure is written to include the splitters, thereby handling all cases.) PUT's not supporting disconnect need to see constant signaling at their RX ports, or else they drop out of BIST-L mode, and restart sending the COMINIT sequence. The content of the signaling needed to keep the RX in BIST does not matter, as long as it is NRZ-like data of sufficient amplitude to prevent the RX squelch detection circuitry from thinking the signal has been lost.

The procedure for configuring non-disconnect PUT's consists of connecting both the BISTGEN and the SSG to the pickoff tees as shown in Figure F-1 above, however the SSG output is initially turned OFF. The PUT's BIST mode is initiated by the BISTGEN, and the PUT enters the loopback state. Once this state is entered, the SSG output is simultaneously turned on (sending a mixture of both the SSG and BISTGEN signals into the PUT), and the BISTGEN SMA connections are removed from the pickoff tees, and the unused tee ports are terminated with 50-ohm SMA terminators. This leaves the SSG connected to the PUT RX through the pickoff tees, with the PUT still in BIST-L mode. As long as the signal from the SSG is not interrupted, the PUT should stay in BIST mode, and the test may be run.

The final step is to connect the Frame Error Counter to the PUT TX signal (as shown in Figure F-1, where the BISTGEN logical block is replaced with the Frame Error Counter, and the BISTGEN side of the splitters is terminated with 50-ohm SMA loads (as there is not TX signal coming out of the Frame Error Counter, i.e., it is RX-only.)

Note that an additional side benefit to using the splitters is that rather than terminating the unused splitter ports with 50-ohm SMA terminators as described above, another option is to instead connect the DSO to these ports (as the DSO input is as good a termination, if not better, than SMA loads), and use the DSO to simultaneously monitor the test signal going into the PUT as it is being tested. This is very convenient, as it allows for real-time observation of the jitter as the test is being performed (which also reduces potential for human error, as the tester can verify that the DJ/RJ settings are correct as the test is running.)

F.2 - Configuring the SSG to send an MFTP or Framed COMP signal:

- To create an **MFTP** pattern. Go to the **Data** tab. Enter a pattern length of 32 bits. Edit the pattern to read "1100 1100 1100 1100 1100 1100 1100 1100".
- To create **Framed COMP**: Use Agilent Pattern Loading Tool to upload pattern file to 81134A.
- Configure the initial data amplitude by going to the **Channel** tab, and under Channel 1 (orange screen) enter an **Offset of 0mV**, and Amplitude of **405mV (Gen1)**, or **375mV (Gen2)**. Additionally select **Data, Normal**, and **NRZ** under the Channel 1 settings. Select the delay control input to **250ps**. Levels **Normal**.
- Select **Pulse/Pattern Mode** in the upper part of the display and select the required frequency. Enter **1.500000000GHz** for RSG-01 and **3.000000000GHz** for RSG-02.
- Turn on the transmitter by pressing the two Output buttons for the differential signal on the front panel.
- Under the **AUX screen** of the **81134A**, set all values as shown in Figure F-2, below.

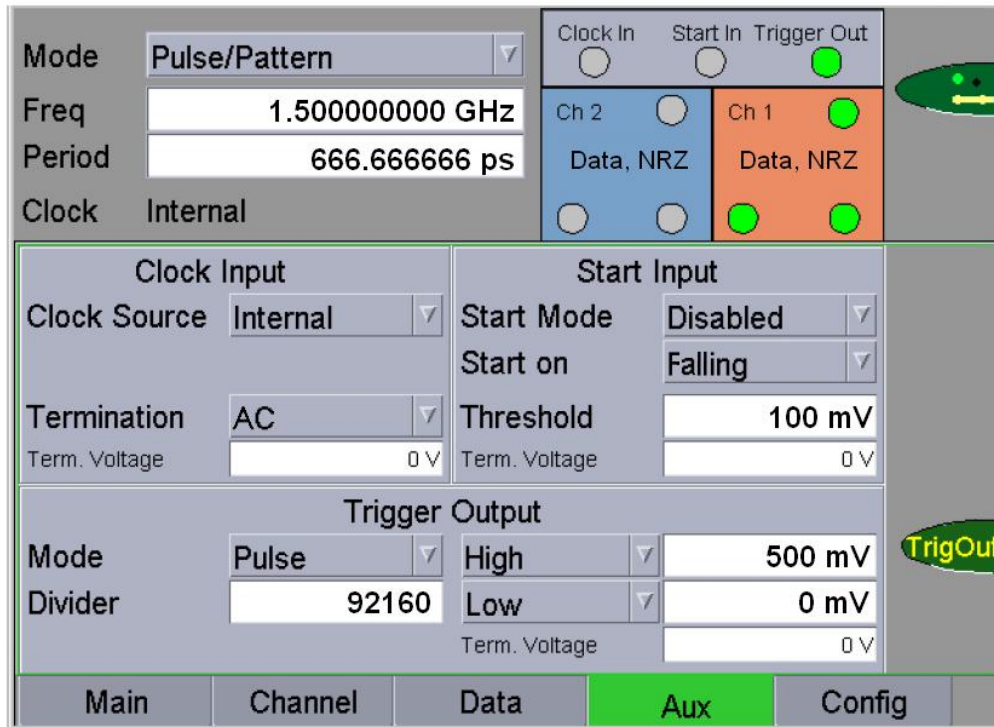

Figure F-2: 81134A Aux Screen Showing Proper Test Settings

F.3 – Adjusting the Output Amplitude

- To adjust the output amplitude on the 81134A, go to the **Channel** tab, and under the settings for **Channel 1** (the orange screen), enter the amplitude value under the **Ampl** field.

F.4 – Adjusting the Random Jitter (RJ)

- To adjust the RJ, simply increase/decrease the output of the **Noisecom PNG-7110 Programmable Noise Generator** by pressing the **NOISE ATTEN** button, entering a numeric value using the keypad, then pressing **ENTER**.
- (Note that it is also possible, after pressing **ENTER**, to simply press the **1 (INC)**, and **2 (DEC)** buttons to increment and decrement the noise amplitude by fractional steps.)

F.5 – Adjusting the Deterministic Jitter (DJ)

- To adjust the Deterministic Jitter via the **33250A Function/Arbitrary Waveform Generator**, turn on the output in pressing the **Output** button at the front panel. Select a sinusoidal waveform by pressing the **Sine** button at the front panel. Use the **Frequency** hotkey to set the required frequency. Calibrate the deterministic jitter by adjusting the Amplitude and observing the jitter reading on the JMD.

Serial ATA Logo Working Group

Appendix G – Using the Agilent N4219B Serial ATA Probe as the Frame Error Detector

Purpose: To define a procedure for initial setup, configuration, and verification of the SATA Probe, for the purpose of being used as the Frame Error Detector.

References:

- [1] Serial ATA Interoperability Program Revision 1.2 Unified Test Document, Section 2.16

Last Modification: November 13, 2006

Discussion:

Prior to running the actual stressed receiver tests, it is necessary to perform several steps to configure and verify proper operation of the Frame Error Detector. One possible implementation of a Frame Error Detector utilizes the Agilent N4219B SATA Probe in conjunction with an appropriate Logic Analyzer.

G.1 – Probe Setup and Configuration

1. Connect the N4219B Serial ATA probe to the logic analyzer according to the installation instructions.



2. Make sure that POD 1,2 and POD 3,4 for Port 1 are connected to the logic analyzer. A connection for Port 2 is not required for this test.
3. Power up the N4219B and the logic analyzer and start from the default settings. The following screen shot shows a typical start-up screen.

Serial ATA Logo Working Group

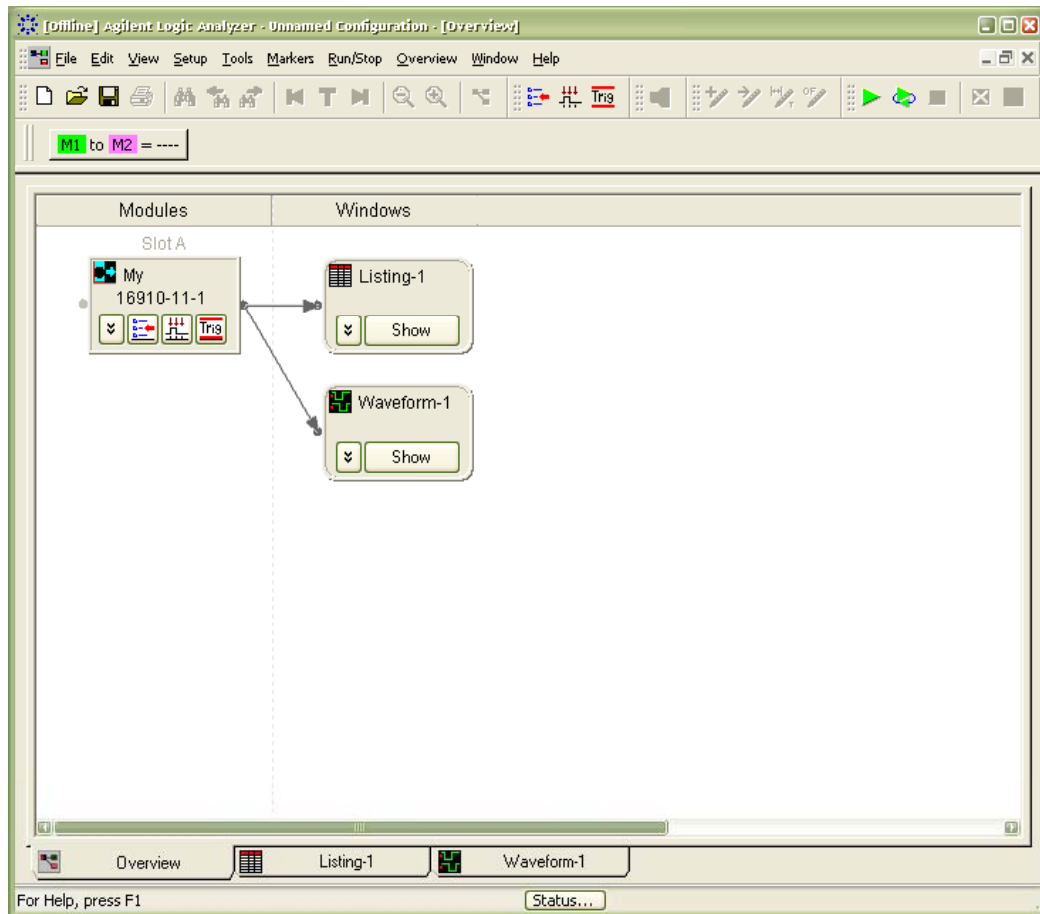

4. Select File-> Open and browse to the N4219B default configurations:

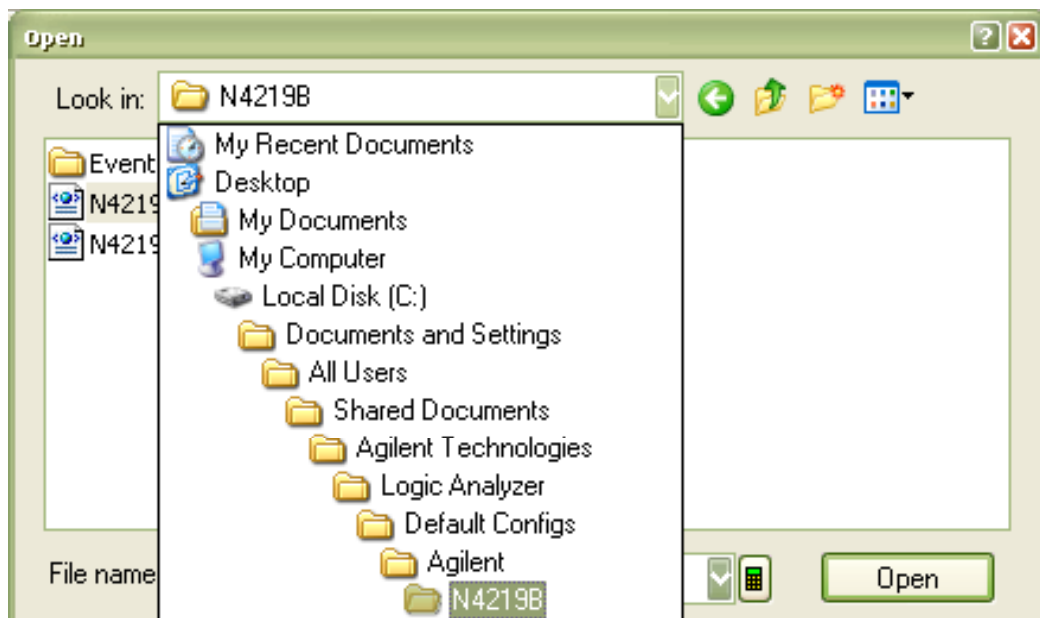

5. Select the N4219B_1.xml file and open it:

Serial ATA Logo Working Group

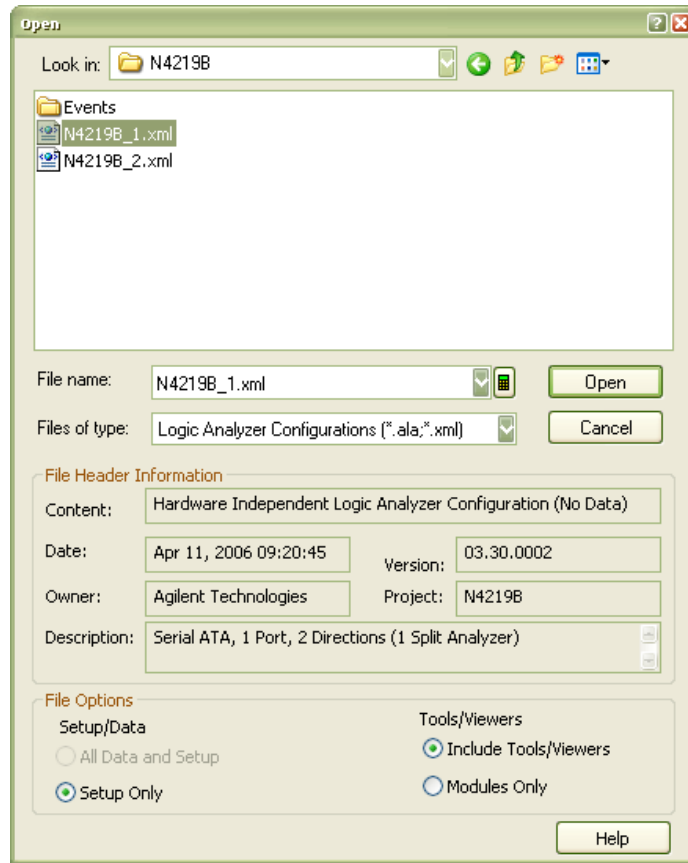

6. The logic analyzer will open a number of tabs and show the following default configuration:

Serial ATA Logo Working Group

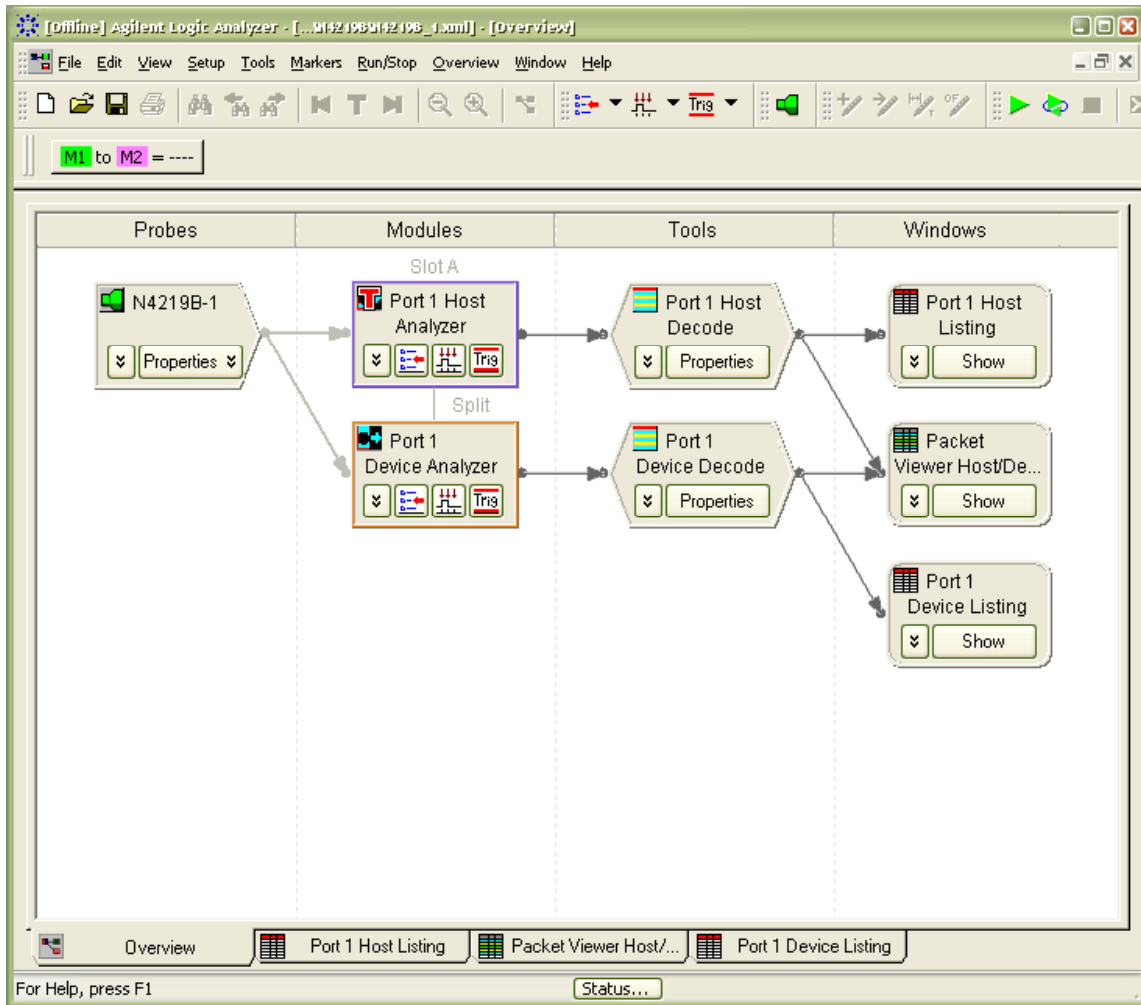

The Overview tab gives access to all required features for this test. For setup the N4219B Properties and the Port1 Device Analyzer Trigger will be configured later. When running the FER test the Status button at the bottom of this window will lead to the test results.

7. Make sure your PUT is transmitter output is connected to Port 1 HR/DT:



The HT/DR of Port 1 and Port 2 won't be connected for this test.

Serial ATA Logo Working Group

- Open the N4219B Properties Setup from the Overview tab of the logic analyzer. Make sure your settings are as shown below.
Set the Port 1 Probe Rate according to your test speed requirements. For RSG-01 this is 1.5Gbps and for RSG-02 this is 3Gbps. Once the PUT is transmitting the Port 1 Device Status will show the link status and speed.
The definition of Primitive Recognizers or Events is not required for this test.

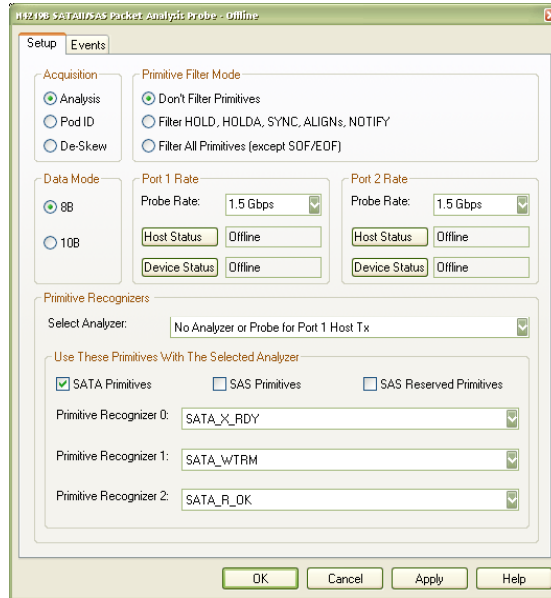

- Open the Port 1 Device Analyser Trigger menu and define the trigger as illustrated below:

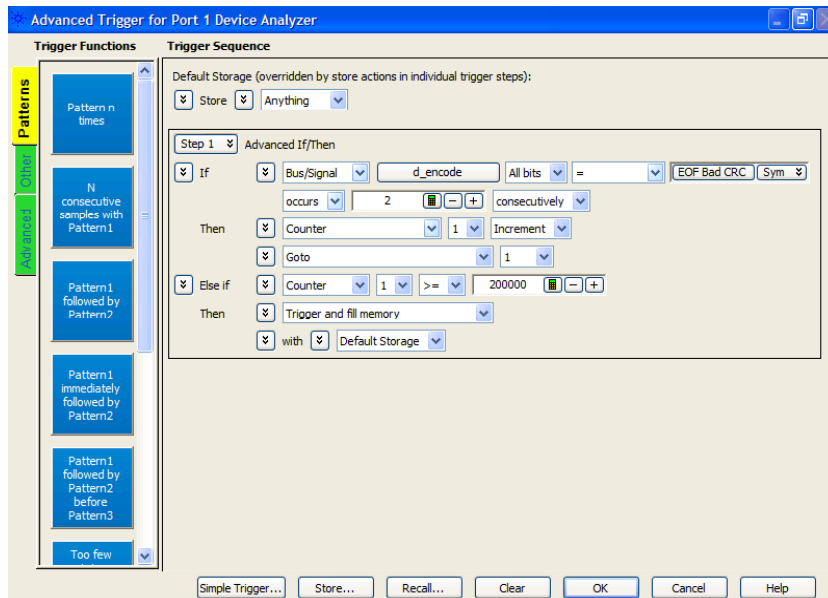

The underlying idea of this trigger definition is to use one of the logic analyzer's internal real-time counters to count frames with wrong checksum (EOF Bad CRC). Based on the N4219B design this event will occur twice for each frame. To count the number of events correctly it is important to know that EOF Bad CRC will occur 2 times in a consecutive manner for 1 wrong frame.

The Else if part of the trigger is not required for this test but avoids a Warning message that indicates a trigger

Serial ATA Logo Working Group

with no exit path.

10. Before starting the logic analyzer for FER test open the Status window from the main overview:

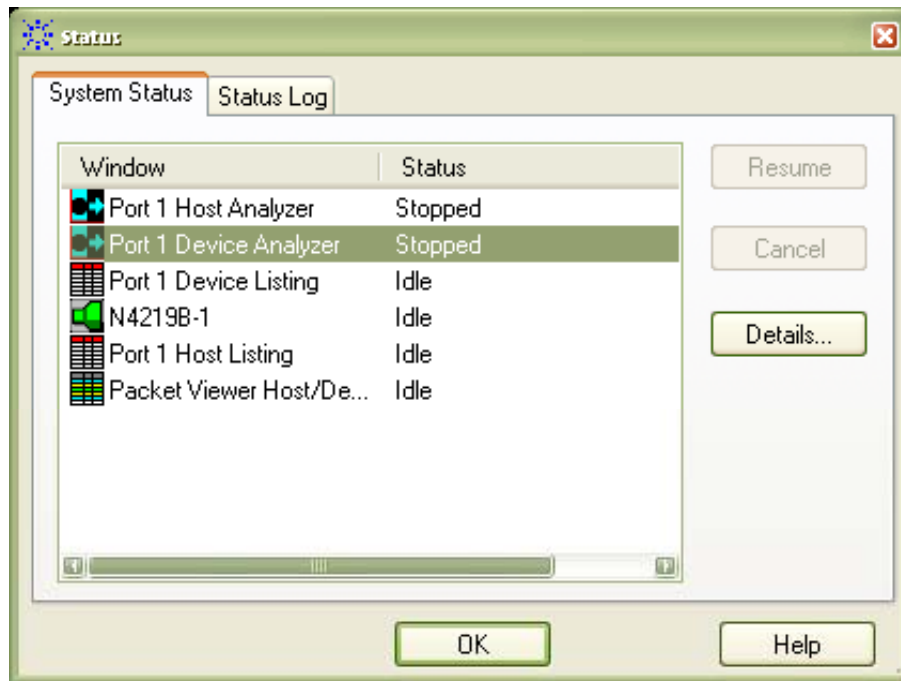

11. Open the Details for Port 1 Device Analyzer:

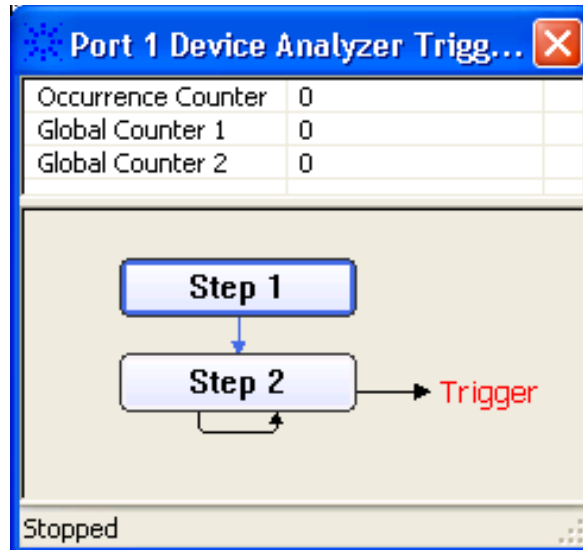

The Global Counter 1 values gives the actual number of FER errors in real-time while running the test. Based on the pass/fail criteria for RSG-01 and RSG-02 the test may be interrupted if the number of FERs reached its limit.

The counter resets each time the logic analyzer is started. Thus stop and start the logic analyzer once the setup is ready for the FER test.

Serial ATA Logo Working Group

Appendix H – Using the Crescent Heart Software SATA-II Probe as the Frame Error Detector

Purpose: To provide a procedure for using the Crescent Heart Software SATA-II Analyzer Probe as an alternate Frame Error Detector.

References: None

Last Modification: April 28, 2007

Discussion:

Appendix G of this MOI defines a procedure for using the Agilent N4219B Serial ATA Probe and associated Logic Analyzer as a Frame Error Detector. An alternative to this Frame Error Detector implementation is the Crescent Heart Software SATA-II Probe Adapter, which provides a simple means for monitoring and counting a variety of SATA error conditions, in addition to CRC-errored frames.

Note that a complete user's manual for the SATA-II Probe can be obtained from the Crescent Heart Website, as well as an abbreviated manual for using the SATA-II probe for Frame Error Detection purposes. (See <http://www.c-h-s.com/SATA.shtml>) The following set of instructions provides a general procedure, but refer to the formal product documentation if additional detail is desired.

After installing the Application software on a standard USB-equipped PC, and launching the application, you should see the following screen:

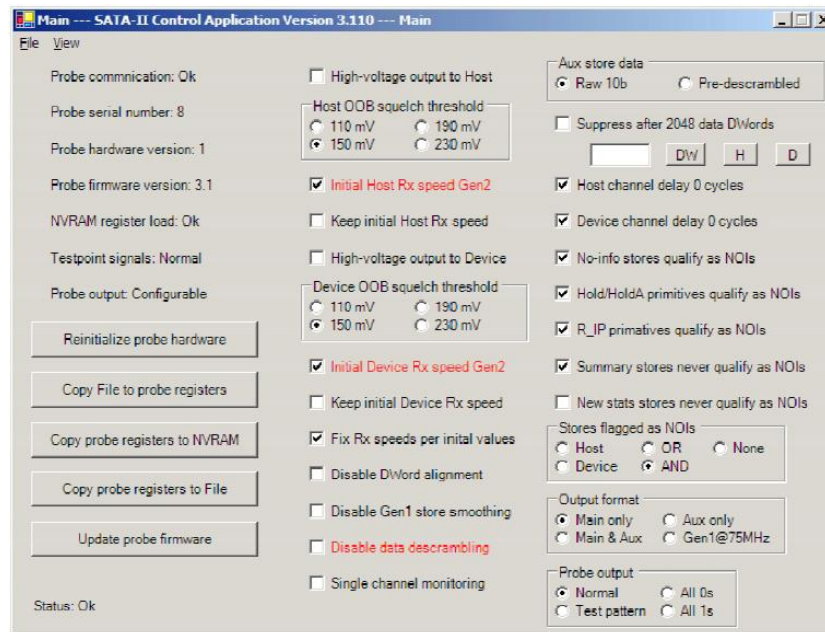

Figure H-1: SATA-II Control Application Main Window

Configure the settings as shown in Figure H-1 above (making note to properly de-select the 'Initial Host RX speed Gen2', and 'Initial Device RX speed Gen2' boxes if Gen1 PUT testing is being performed.)

Once the Main Window settings are configured, go to **View->Counters** to select the Counters window, shown in Figure H-2, below:

Serial ATA Logo Working Group

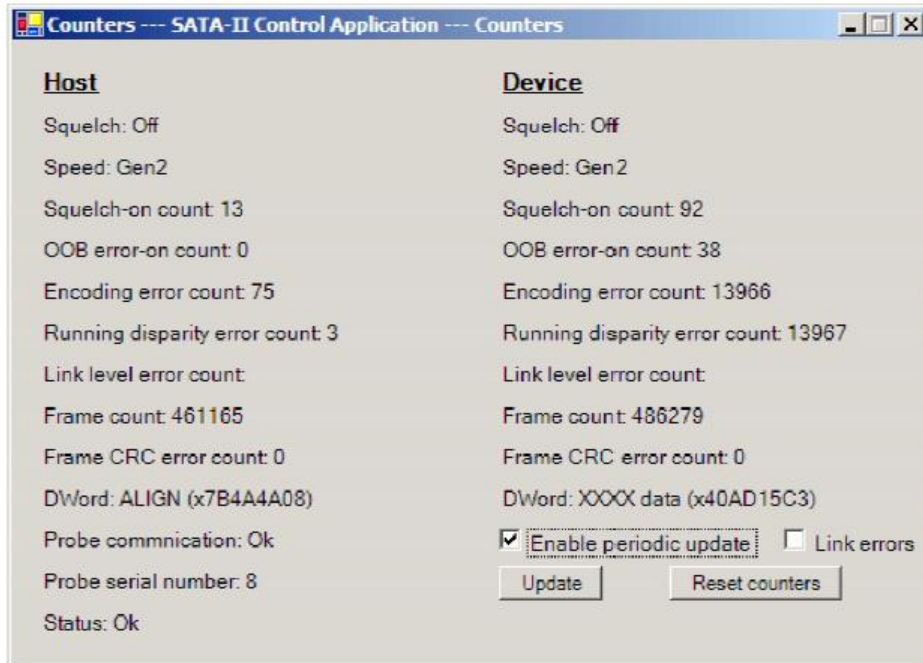

Figure H-2: Counters Window

The **Frame Count** and **Frame CRC Error Count** values are the most pertinent to the RSG test procedure. Making sure the **Enable Periodic Update** box is checked, the **Frame Count** value should increment when the probe is connected and functioning properly. Note that it is generally beneficial in every test setup to verify that the **Frame CRC Error Count** counter is also functioning properly by loading an intentionally CRC-errored frame pattern into the SSG and sending it through the loopback-enabled PUT. In this case the CRC Error counter should increment for every received frame.

Note that for RSG testing, it is normal for the **Link Level Error Count** counter to increment during testing. This is simply due to the fact that the normal Link Level protocol is not being obeyed by the PUT during the RSG test, and thus this counter may be ignored.

Also note that in some cases it may be observed that the other error counters may increment during a test. Although relatively uncommon, it is possible for Running Disparity or Encoding Errors to occur on the wire that will be detected as errors by the probe, but NOT cause a CRC error to occur. This is due to the fact that these errors sometimes occur OUTSIDE of the SATA frame (i.e., the contents covered by the CRC). Because the SATA RSG test is defined as a **frame error** test (rather than a **bit error** test), these types of errors occurring outside of the CRC-applicable frame are not counted as observed errors, and therefore do not affect the pass/fail criteria for a given PUT. (However it is recommended that if such errors are observed during testing, some effort be made to determine the cause, as such errors should not typically occur for devices operating with a significant degree of receiver margin.)

Serial ATA Logo Working Group

Appendix I – Suggested Initial Amplitude and DJ/RJ Settings for Various SSG Setups (Informative)

Purpose: To provide a table of initial (i.e., pre-calibrated) amplitude, DJ, and RJ, settings for various SSG's.

References: None

Last Modification: June 7, 2007

Discussion:

In this MOI, two types of SSG sources are defined (J-BERT vs. 81134A with external modulation source). (Note that both of these setups assume the use of Transition Time Converters (TTC's), and 50/50 power splitters on their outputs. See respective SSG appendices of this document.) This appendix contains suggested starting values for initializing the amplitude, RJ, and DJ settings prior to performing the calibration steps of Appendices B, C, and D. These are informative values intended as initial starting points when performing the calibration procedure.

	81134A+33250A as SSG	81134A+E4432B as SSG	J-BERT as SSG
Gen1:			
Ampl (162.5/325mV)	405mV**	405mV**	(TBD)
RJ (8.57ps RMS)	18.00	18.00	(TBD)
DJ (10MHz)	770mVpp	280mV	(TBD)
DJ (33MHz)	630mVpp	250mV	N/A
DJ (62MHz)	810mVpp	260mV	N/A
Gen2			
Ampl (137.5/275mV)	375mV**	375mV**	(TBD)
RJ (4.285ps RMS)	23.00	23.00	(TBD)
DJ (10MHz)	370mVpp	125mV	(TBD)
DJ (33MHz)	350mVpp	115mV	(TBD)
DJ (62MHz)	370mVpp	120mV	(TBD)

**For eSATA amplitude levels (informative):

Gen1m: Use 270mV to get 120/240mV at 1.5G

Gen2m: Use 310mV to get 120/240mV at 3.0G

Table I-1: Suggested Initial Settings for Various Equipment Setups

Serial ATA Logo Working Group

Appendix J – Using the Agilent N5990A Test Automation Software Option 103

Purpose: To document the use of the N5990A Test Automation Software Option 103 for RSG-01 and RSG-02 tests. (N5990A is also referred to as ‘Valiframe’.)

References: None

Last Modification: June 05, 2007

Discussion:

The Agilent N5990A-103 test automation software automates all manual steps listed under RSG-01 and RSG-02 in this document. All calibrations and measurements follow the same proceedings.

J.1 – General Setup:

The Setup consists of following components:

- Agilent 81134A as SSG
- Agilent 33250A or Agilent ESG (model number) as sine source for generating sinusoidal jitter
- NoiseCom noise source as listed above for generating random jitter.
- Agilent DSO80000 series oscilloscope as JMD
- Agilent 16800 series or 16900 series Logic Analyzer + N4219BA as Frame Error Detector
- PC with Windows XP and N5990A Option 130 Software as Host PC

Alternatively the following instruments are also supported:

- Crescent Heart Software SATA Probe as Frame Error Detector.
- Agilent JBERT

The cabling is identical to the setup for the manual test procedure described before in this document. The following diagram shows how to connect the instruments to the host PC.

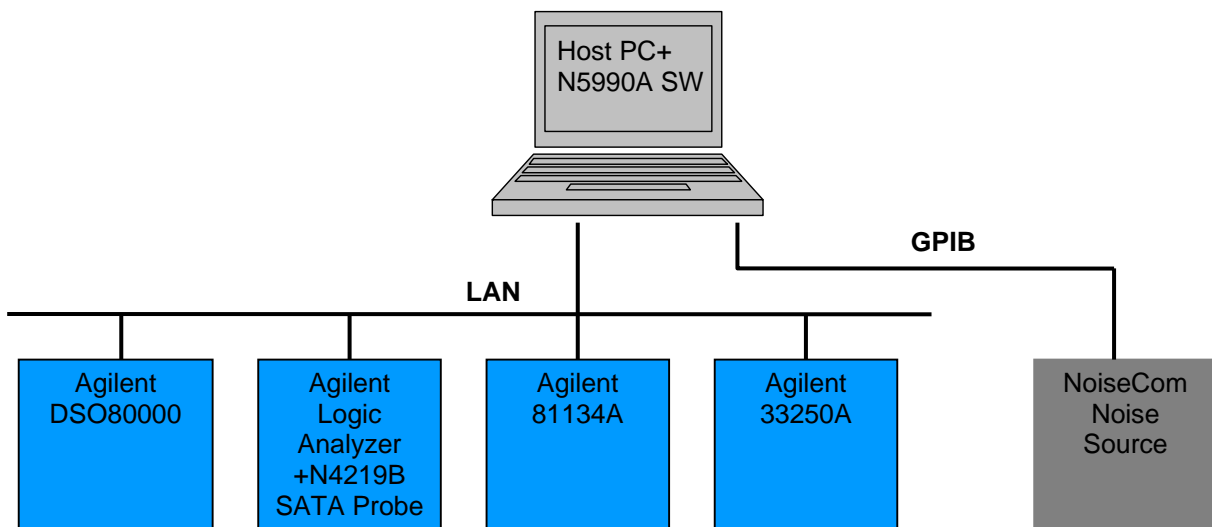

Figure J-1: Test Equipment Network Diagram

J.2 – Installing and Configuring the Software:

Before installing the Agilent N5990A Test Automation Software Option 103 the following components should be installed on the Host PC:

- Microsoft .NET Framework 1.1

Serial ATA Logo Working Group

- Microsoft .NET Framework 2.0
 - Microsoft Excel 2003 or higher
 - Agilent IO Libraries Suite 14.2
 - Agilent T&M Programmers Toolkit Redistributable Package 1.1
- On the Agilent 16900A Logic Analyzer this software must be installed:
- VFAg1600AServer

After installing Valiframe “Valiframe Station Configuration” should be called once the setup the different addresses of the instruments:

- Start Valiframe Station Configuration

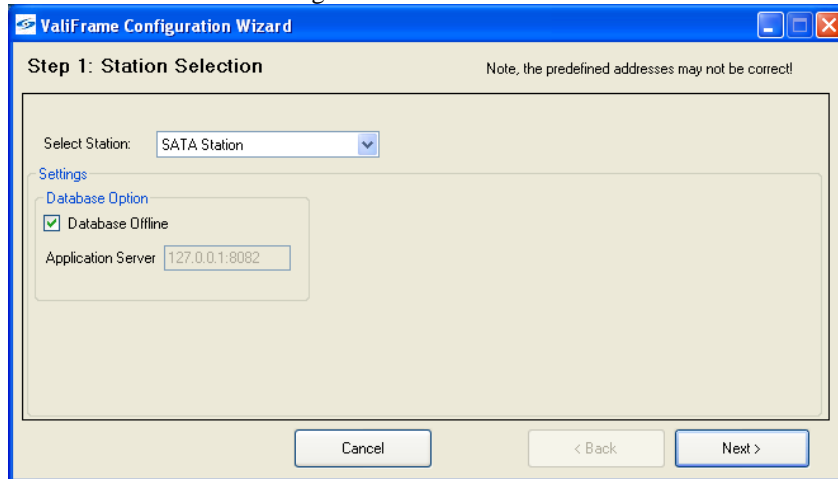

Press “Next”.

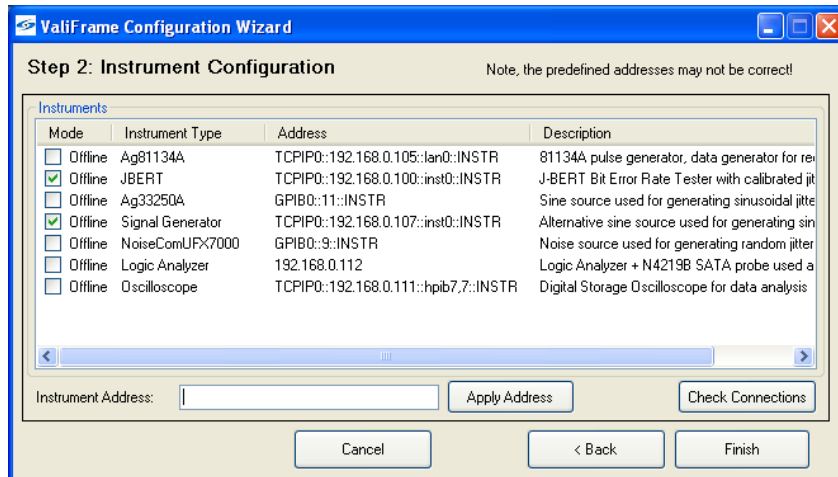

Offline Flags of J-BERT and Signal Generator should be checked. Offline flags for all other instruments should be unchecked. The addresses of the instruments must be changed. Press “Finish”.

J.2 – Test RSG-02: Gen2 (3.0Gb/s) Receiver Jitter Tolerance Test

- Start Valiframe.

Serial ATA Logo Working Group

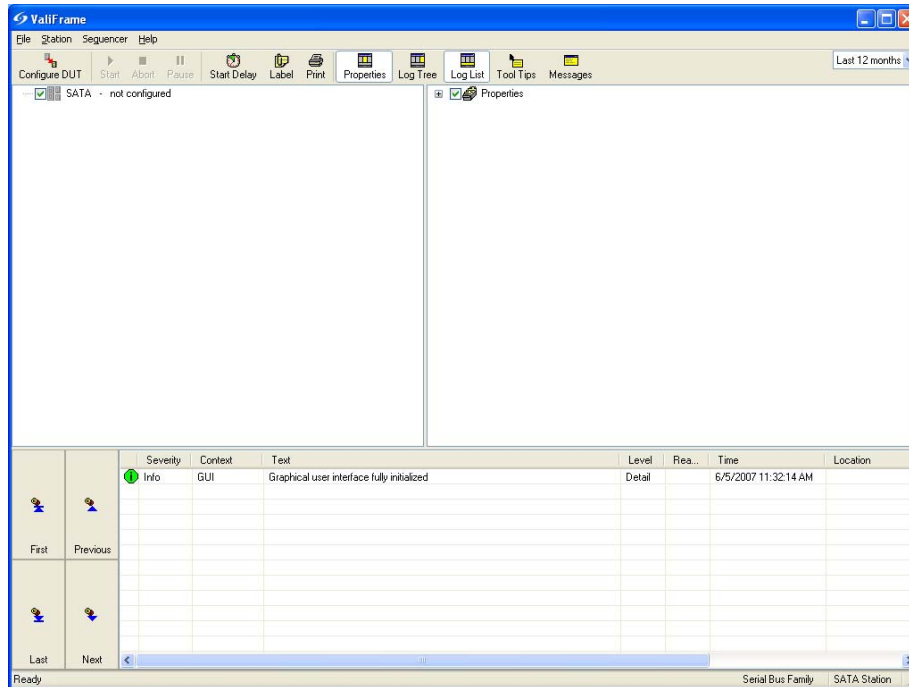

- Press "Configure".

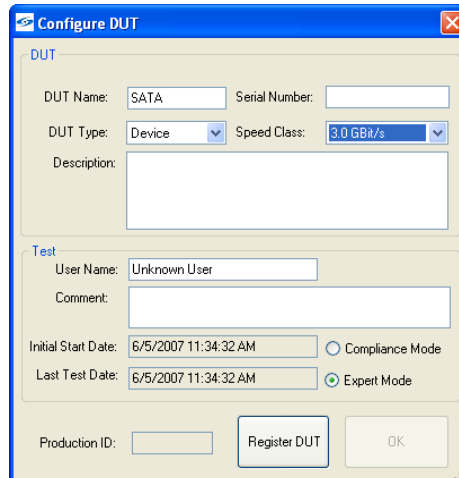

- Select Speed Class 3.0 GBit/s and press Register DUT and then OK.

Serial ATA Logo Working Group

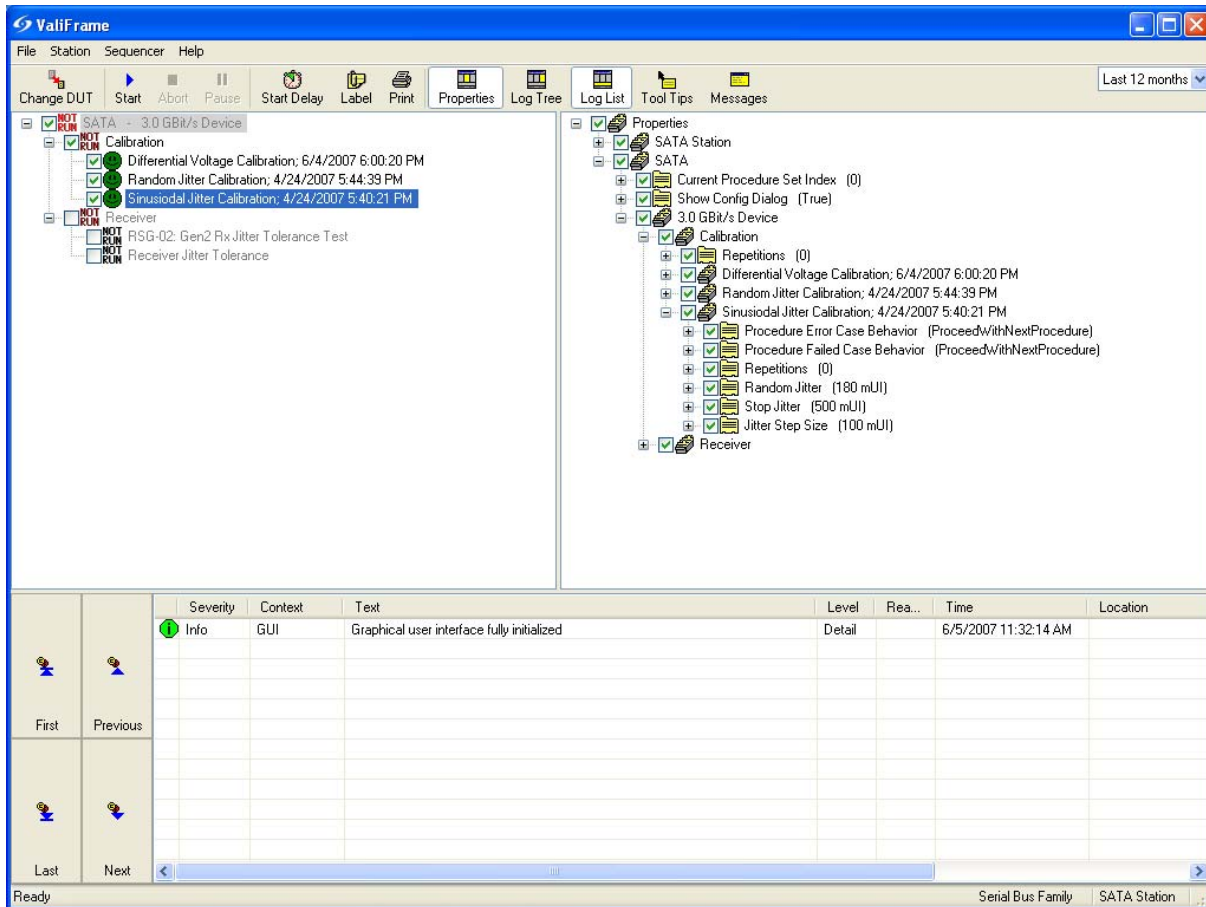

- Select “Differential Voltage Calibration”, “Random Jitter Calibration” and “Sinusoidal Jitter Calibration” from the test tree on the left side of the window.
- Press “Start”. Then you are prompted to change the electrical connection (according Appendix B – SSG Calibration Procedure using Agilent DSO081204 as the JMD).
- When the calibration procedures are finished the indicators next to the calibration routines should be green. The calibration routines should be performed once a day. The date and time of the last calibration is noted next to the calibration routines names in the test tree.

Serial ATA Logo Working Group

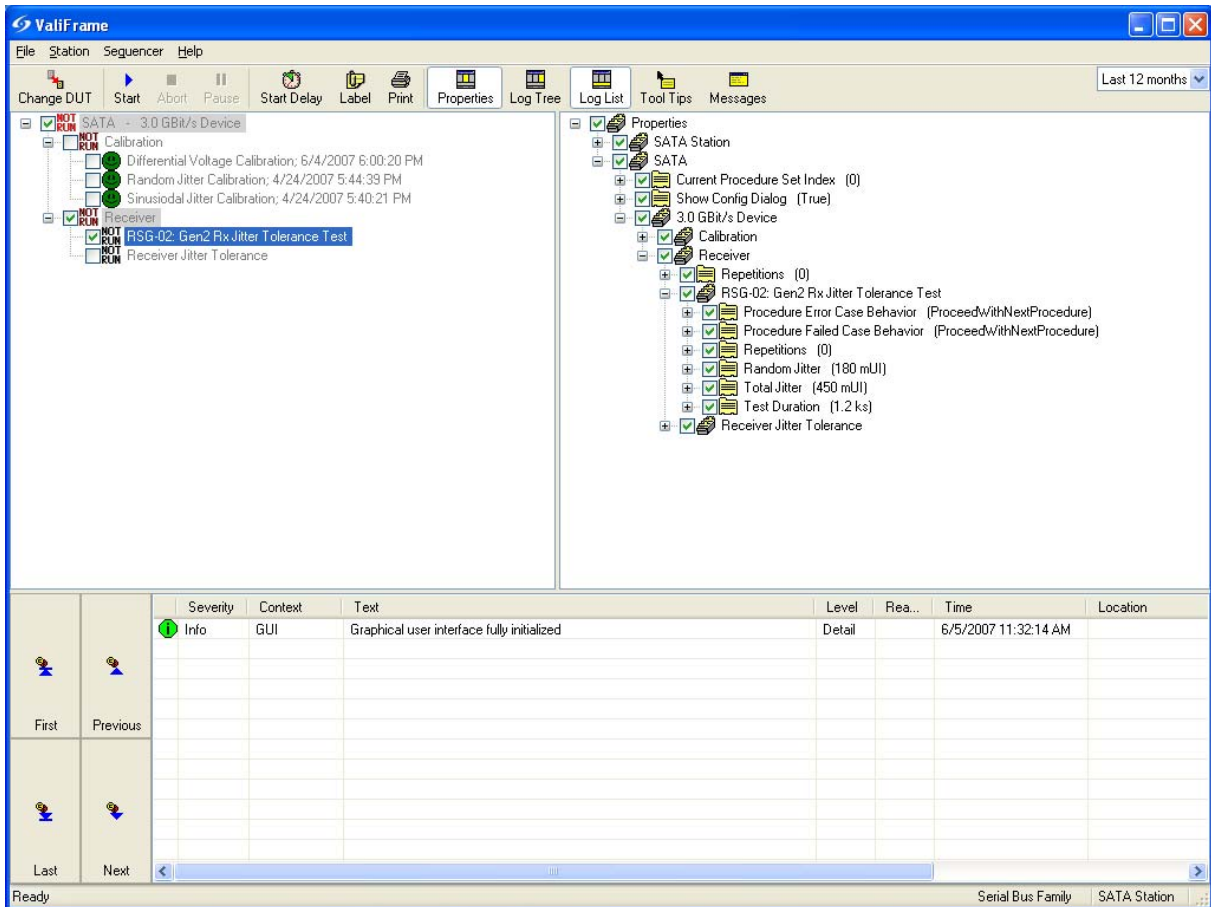

- Select the “RSG-02: Gen2 Rx Jitter Tolerance Test” procedure.
- Press “Start”. Then you are prompted to change the electrical connection (according group1 Test RSG-02) .
- After one hour the test RSG-02 is finished. When the green indicator next to the test name is green the DUT has passed the test. For a detailed test report double click on the test and an excel sheet will open:

Serial ATA Logo Working Group

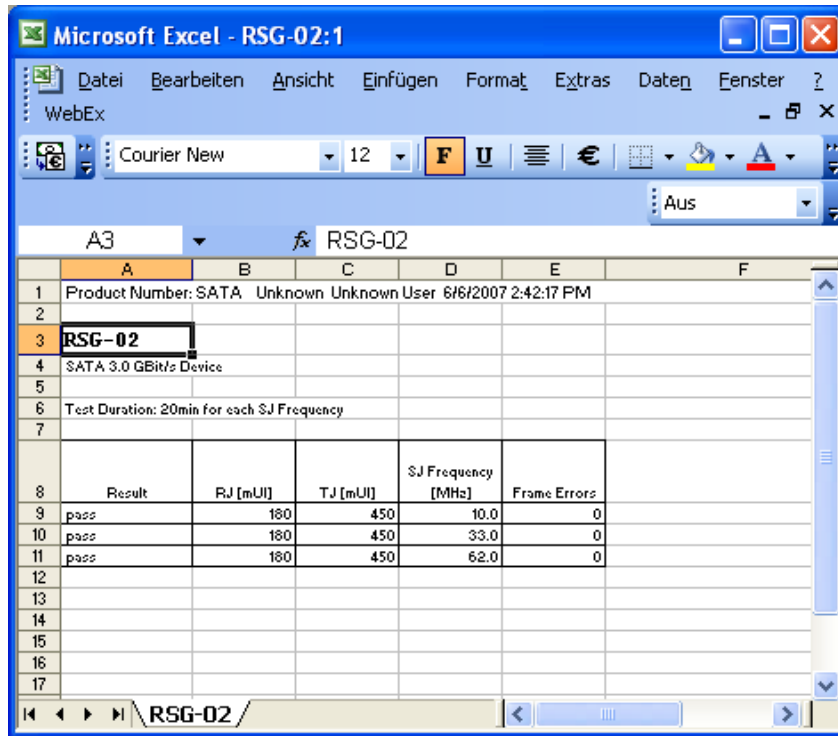

The screenshot shows a Microsoft Excel spreadsheet titled "RSG-02:1". The spreadsheet contains test results for a SATA 3.0 GBit/s device. The data is as follows:

	A	B	C	D	E	F
1	Product Number: SATA Unknown Unknown User 6/6/2007 2:42:17 PM					
2						
3	RSG-02					
4	SATA 3.0 GBit/s Device					
5						
6	Test Duration: 20min for each SJ Frequency					
7						
8	Result	RJ [mUI]	TJ [mUI]	SJ Frequency [MHz]	Frame Errors	
9	pass	180	450	10.0	0	
10	pass	180	450	33.0	0	
11	pass	180	450	62.0	0	
12						
13						
14						
15						
16						
17						

J.3 – Test RSG-01: Gen 1(1.5Gb/s) Receiver Jitter Tolerance Test

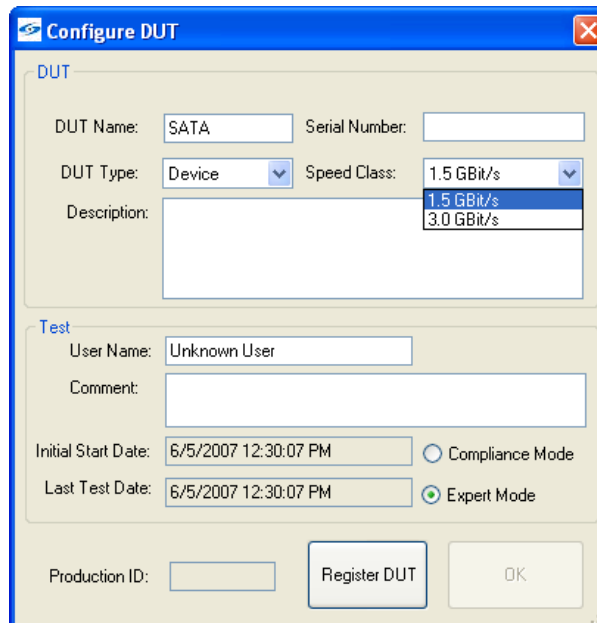

The "Configure DUT" dialog box is shown with the following fields and options:

- DUT**
 - DUT Name: SATA
 - Serial Number: [Empty]
 - DUT Type: Device
 - Speed Class: 1.5 GBit/s (dropdown menu is open showing 1.5 GBit/s and 3.0 GBit/s)
 - Description: [Empty]
- Test**
 - User Name: Unknown User
 - Comment: [Empty]
 - Initial Start Date: 6/5/2007 12:30:07 PM
 - Last Test Date: 6/5/2007 12:30:07 PM
 - Compliance Mode:
 - Expert Mode:
- Production ID: [Empty]
- Buttons: Register DUT, OK

- Press "Configure DUT" or "Change DUT"
- Select "1.5 GBit/s" for Speed Class and press "Register DUT" and "OK".
- Now proceed as described in J.2 Test RSG-02.